

# UMHLAHLANDLELA WOKWAKHIWA KOPHAHLA LOTSHANI ENINGIZIMU AFRIKA



**THATCHERS ASSOCIATION  
OF SOUTH AFRICA**

UMHLAHLANDLELA WOKWAKHIWA KOPHAHLA  
LOTSHANI ENINGIZIMU AFRIKA

---

UMHLAHLANDLELA WOKWAKHIWA  
KOPHAHLALOTSHANIENINGIZIMU  
AFRIKA KA– 2018 Isihumusho sesi-2

Lo mbhalo uphoqelekile Kubanikazi, Abamakontileka Bokwakhiwa Kophahla Lotshani, Abamakontileka Okwakha, Abaqambizimo (*Architects*), Abathathi Zinqumo, Onjiniyela kanye Nezinhlangothi Ezinikeza Iziqu (izitifiketi).

Ukuze uthole ulwazi olwengeziwe ngolwazi olukulo mhlahlandlela, sicela uxhumane ne-:

Thatchers Association of South Africa

Private Bag X 1015

Lyttelton

0140

South Africa

+27(0)83-283-8429

admin@sa-thatchers.co.za

WONKE AMALUNGELO AGODLIWE

Lo mhlahlandlela omaqondana nokwakhiwa kophahla lotshani eNingizimu Afrika umbhalo oshicilelwe Wenhlangothi Yabakha Uphahla Lotshani eNingizimu Afrika futhi ayisona isilinganiso.

Isilinganiso Sophahla Lotshani ngu-SANS 10407 – 2015 Isihumusho sesi-2

Lo mhlahlandlela yimpahla Yenhlangothi Yabakha Uphahla Lotshani baseNingizimu Afrika futhi akukho ngxenye yalo mbhalo oshicilelwe engasuswa noma ishintshwe noma ifakelwe ulwazi olusha ngaphandle uma isinqumo sithathwe ngabantu abayisibalo esikhulu Sekomiti Lesigungu le-TASA.

# UMHLAHLANDLELA WOKWAKHIWA KOPHAHLA LOTSHANI ENINGIZIMU AFRIKA

---

## IBIKA

Inhlangano Yabakha Uphahla Lotshani baseNingizimu Afrika (*i-Thatchers Association of South Africa (i-TASA)*) yakha lo mbhalo ukufinyelela isidingo esenyukayo semihlahlandlela eqondile ekwakhiweni kanye nasekugcinweni kophahla lotshani olusezingeni elihlonipha izidingo zamaZinga aseNingizimu Afrika ahlukile Kuzwelonke

Ukuhlonipha izidingo eziwubuncane yisidingo. Lo mhlahlandlela osebenzayo uchaza okokwenza, inqubo kanye nezindlela zokuhlola okumele zisetshenziswe ukuze kuhlonishwe lezo zidingo

Lo mbhalo uhambisana nemiyalelo Yokwakha Kuzwelonke kanye ne-SANS 10407 – 2015 Isishicilelo se-2. Singalindela ukuthi lawa mazinga aphoqelelwe esikhathini esizayo. Lo mbhalo uzosiza imboni ukulungiselela loku.

Okusemqoka kakhulu, ukuthi lo mbhalo uzokwakha futhi ukuzethemba embonini. Abasebenzisi kanye Nabakha Uphahla Lotshani bazokwazi ukusebenzisa loku njengombhalo oyireferensi oweseka Amazinga Kuzwelonke.

Loku kwaba yisidingo esikhulu kakhulu ngoba izinga lamakhono labasha abangena embonini kanye nokuguquguquka kwezici zezinto zokwakha eziluhlaza kunomthelela omkhulu ezingeni lomkhiqizo wokucina.

Lo mbhalo uphoqelekile kwabakha uphahla lotshani, kwabamakontileka okwakha, kubaqambizimo, kwabathatha izinqumo, konjiniyela kanye nezinhlangano ezinikeza izitifiketi. I-TASA kumele ihalaliselwe ngomzamo kanye nangokubhalwa ngokuphelele kwalo mbhalo okuzonikeza ulwazi olwakha imboni enempilo nethembeke kakhulu ngokwenza ukuthi abantu abaqophisanayo babe sezingeni elilinganayo.

Thina e-SATAS siyaziqhenya ukubambisana ne-TASA maqondana nokunikezwa Kwezitifiketi kumalungu ayo. Kithina njengenhlango Enikeza Ngezitifiketi kusemqoka ukuthi senze ngokufanele nangokuqondile kuzitifiketi kanye nezinhlobo zethu ngakho-ke le mihlahlandlela izosiza futhi ukuthi senze ngokungacwasi kanye nangendlela efanele.

Siyabahalalisela futhi siyabonga kubo bonke abantu abanikeze imibono ukwenza lo mbhalo ube ngumbhalo oseqophelweni eliphezulu ongumhlahlandlela ozokwenza umehluko embonini.

Ngu-Abe Stears  
Umqondisi Ongumphathi  
We-SATAS

SOUTH AFRICAN TECHNICAL AUDITING SERVICES (PTY) LTD  
PO BOX 4443  
RIETVALLEIRAND 0174



## UKUBONGA

Inhlangano Yokwakha Uphahla Lotshani yaseNingizimu Afrika ifisa ukubonga i-SAWPA (*the South African Wood Preservers Association*) ngoxhaso lwabo ngezimali ukulungiselela lo mhlahlandlela.



### CHOOSE THE CORRECT HAZARD (H) CLASS:

- H2 – **Low Hazard:** Inside above ground
- H3 – **Moderate Hazard:** Outside above ground
- H4 – **High Hazard:** Outside in ground
- H5 – **High Hazard:** Outside in contact with heavy wet soil or in fresh water
- H6 – **High Hazard:** Prolonged immersion in sea water



FOR MORE INFORMATION ABOUT SAWPA MEMBERS  
AND HOW TO CONTACT THEM. CONTACT:

Tel: 011 974 1061  
sawpa@global.co.za  
www.sawpa.co.za



UMHLAHLANDLELA WOKWAKHIWA KOPHAHLA  
LOTSHANI ENINGIZIMU AFRIKA

---

PROMOTING TREATED TIMBER AND THE USE OF TREATED TIMBER  
PRODUCTS PRODUCED BY SAWPA MEMBERS

*(UKUTHUTHUKISA AMAPULANGWE (UTHIMBA) ASETSHENZIWE KANYE  
NOKUSETSHENZISWA KWEMIKHIQIZO YAMAPULANNGWE  
ASETSHENZIWE EKHIQIZWA NGAMALUNGU AKWA-SAWPA)*

CHOOSE THE CORRECT HAZARD (H) CLASS

*KHETHA IKILASI ELIFANELE LENGOZI U-(H)*

H2- Low Hazard: Inside above ground-Ingozi Ephansi:

*Ngaphakathi phezu kwendawo ephansi*

H3- Moderate Hazard: Outside above ground

*Ingozi Ephakathi: Ngaphandle ngaphezu kwendawo ephansi*

H4- High Hazard: Outside in ground

*Ingozi Ephezulu: Ngaphandle phakathi kwendawo ephansi*

H5- High Hazard: Outside in contact with heavy wet soil or in fresh water

*Ingozi Ephezulu: Ngaphandle ixhumana nenhlabathi emanzi esindayo noma  
ngaphakathi kwamanzi amasha*

H6- High Hazard: Prolonged immersion in sea water

*Ingozi Ephezulu: Ukuhlala njalo ifakwe ngaphakathi kwamanzi olwandle*

FOR MORE INFORMATION ABOUT SAWPA MEMBERS AND HOW TO  
CONTACT THEM. CONTACT

*UKUZE UTHOLE ULWAZI OLWENGEZIWE MAYELANA NAMALUNGU E-  
SAWPA NOKUTHI UNGAXHUMANA NABO KANJANI. XHUMANA NO-*

Ucingo: 011 974 1061

[sawpa@global.co.za](mailto:sawpa@global.co.za)

[www.sawpa.co.za](http://www.sawpa.co.za)

UMHLAHLANDLELA WOKWAKHIWA KOPHAHLA  
LOTSHANI ENINGIZIMU AFRIKA

## UKUBONGA

## AMALUNGU E-TASA



We are the only company to specialise exclusively in thatch insurance and have been doing so for over 20 years.

[www.fra.co.za](http://www.fra.co.za)

Authorised Financial Services Provider FSP 2317  
Underwritten by Compass Insurance Company Limited FSP 12148

**MATT PENNEFATHER**  
Director



Tel: +27 13 710 1  
Cell: +27 82 555  
Email: [matt@lctt.co](mailto:matt@lctt.co)  
Website: [www.lctt.co](http://www.lctt.co)

**TREATED  
TIMBER  
PRODUCTS**

The advertisement for Waterfront Thatchers features a photograph of a large, modern house with a prominent, steeply pitched, yellow thatched roof. The house is set against a clear blue sky with some bare trees in the foreground. In the top left corner, there is a logo for "WATERFRONT THATCHERS" with a stylized thatched roof icon above the text. To the right of the logo, the text reads "Bringing the outside inside, making nature your home..." followed by the website "www.waterfrontthatchers.co.za" and the phone number "083 471 8298".

UMHLAHLANDLELA WOKWAKHIWA KOPHAHLA  
LOTSHANI ENINGIZIMU AFRIKA

---

OKU QUKETHWE

	Inamba yekhasi
IZINCAZELO	10
INQUBO YEPHROJEKTHI	12
Izidingo	12
Abaqambizimo kanye Nonjiniyela	12
Abekontileka Bokwakha Uphahla Lotshani	13
Imibuzo Esizayo Uma Uqasha Owekontileka	14
Imibuzo Engabuzwa Yizinkampani Zomshuwalense	15
Inqubo emaqondana Nephrojekthi Enempumelelo	16
Izibophezelo Zowekontileka	17
Izibophezelo Zeklayenti	17
IZIFANEKISO ZOPHAHLA LOTSHANI	18
IZINTO ZOKWENZA UPHAHLA LOTSHANI	21
Utshani Lokwenza Uphahla Nezintunga Jikelele	21
Incasiselo Yotshani Bokwenza Uphahla	22
Incasiselo Yentunga yaseKapa	25
Incasiselo Yentunga Yasemanzini	26
Ukugcinwa Kotshani Bokwenza Uphahla Endaweni	
Yokusebenzela	26
Ukuhlanza Nokubekwa Ngezinyanda	28
ISAKHIWO SOPHAHLA	29
Ukubekwa Kwesimo Sesakhiwo	29
Izidingo Zamapulangwe	32
Izinsika Zokutshala	32
Amakholomu Ame Aqonda	34
Izinsika	34
Isikhala Somjibe	36
Isikhala Sotshani Obomile	36

# UMHLAHLANDLELA WOKWAKHIWA KOPHAHLA LOTSHANI ENINGIZIMU AFRIKA

---

Izikhala Zogongolo Lokubopha Nokubekwa Esikhundleni	37
Okuhlanganisiwe Kogongolo Olusandandatho	37
Ukuphambukisa	39
Izibopho Zokuvikela Umoya	40
Izikhonkwane Namalathi	41
Izikhala Namalathi	41
Izigodi	42
Izinqulu	44
Izingenqema	44
Oshimula	45
Amapayipi Oshimula Ensimbi	46
Izinqwaba Zoshimula	49
Utshani Bophahla Bokugewalisa	49
<b>UKWAKHA UPHAHLA LOTSHANI</b>	<b>52</b>
Ingqimba Yokunisela	52
Okokubopha Uphahla Lotshani	54
Izikhala Zokubopha	55
Okokubopha Okuqinisayo Kocingo	55
Okokubopha Okuqinisayo Kwentambo	56
Okokuqinisa Utshani Obuntengentenge	57
Ukwenza Uphahla Lotshani Phezu Kokuntengatengayo	57
Ubuhlonzi Bezingqimba Zokwenza Uphahla Lotshani	58
Ukubekwa Kophahla Lotshani	59
<b>IZINKALO</b>	<b>60</b>
Ulwazijikelele	60
Izinkalo Zotshani	62
Izinkalo Zengilazi Eyifayibha	62
Izinkalo Zesimende Nesihlabathi	63
<b>OKUFAKWAYO JIKELELE</b>	<b>66</b>
Okufakwayo Okubenyezelayo	66



UMHLAHLANDLELA WOKWAKHIWA KOPHAHLA  
LOTSHANI ENINGIZIMU AFRIKA

---

---

Okufakwayo Okuyithola (isikhadlana ekwelukweni)	66
Okufakwayo Okuyifasitela Ophahleni Lwendlu	67
Amagatha Ayibhokisi	67
Ingaphambili Lendlu Ngaphandle Elakhiwe Ngotshani	68
Amasilingi Ophahleni Olwakhiwe Ngotshani	68
Ukufakwa Kwegiza	69
Ukulondeka Kwendawo Yokusebenzela	70
UKULUNGISWA NOKUGCINWA KOPHAHLA LOTSHANI	71
UKULUNGISWA KOPHAHLA LOTSHANI NOMA UKWENZA	
UPHAHLA LOTSHANI KABUSHA	74
UKUPHEPHA EMLILWENI	76
Amabanga Okuphepha	76
Izinsizakalo	77
Ukusetshenziswa Kwamakhondaktha	77
Uhlelo Lokuvimbela Umbani ( <i>i-Lightning Protection System (i-LPS)</i> )	78
Ukuminyana Kombani Obenyeza Phansi	79
Izimbambinhlansi	87
Izinhlelo Zokokunethisa	88
Isivimbelamlilo	88
AMANANI AMANDLA KAGESI	89
Amanani Ayisamba Esincane sika-R Okubumbaniswa	
Kophahla	92
Izindawo Zesimo Sezulu eNingizimu Afrika	93
ISIPHETHO	96
UKUBONGA KANYE NAMAREFERENSI	97
UKULANDULA	99

## IZINCAZELO

Ngezinhloso zalo mhlahlandlela, izincazelo ezilandelayo ziyasebenza.

### Isiphetho esiyisidunu

Isiqu sophahla lotshani esisikiwe esiphethweni, esiphansi kakhulu

### Umuntu onekhono

Umuntu othile oqeqeshwe ngokwanele, enesipiliyoni, ulwazi kanye neziqo ukusiza ngokwanele ngesidingo esicacile

### Ukwehluka

Umehluko ophakathi kokwangempela (okusho ukuthi okulinganisiwe) ubukhulu noma isikhundla kanye nobukhulu noma isikhundla esicacisiwe

### Ukwembesa

Isenzo sokuqhwabaza iziphetho eziyizidunu zophahla lotshani noma ukubhekisa phezulu intuga yokwenza uphahla lotshani ngelegathi ukukhiqiza ummango wendawo ofanele

### Ilathi

Ilungu lethimba encane eliyindilinga, eliqondiswe ngokuqondana nokhalo, emagumbini abheke kwesokudla nemijibe, kanye nalapho uphahla lotshani luqondiswe ngakhona

### Isembozo

singaphezu kophahla lotshani

ingqimba yesibili yophahla lotshani engaphezu kwengqimba yokuqala

### Ingqimba yokuthelela

Ingqimba etholakala masishane nje ngaphezu kwezikhonkwane noma amalathi, lapho icala elingaphansi lingavezwa egumbini kwesinye isikhathi

### Udonga olwesekayo

udonga olwakhiwe olusebenza njengodonga olufanele lokuthwala isisindo sophahla olwakhiwe ngotshani

# UMHLAHLANDLELA WOKWAKHIWA KOPHAHLA LOTSHANI ENINGIZIMU AFRIKA

---

## Okuqinisa utshani

irodi eme ngokuqondana nelathi ngaphakathi kwethayi yokhalo futhi ebophela okokwenza kwilathi ukuqinisa uphahla lotshani

## Ukuhlola okunomqondo

ukuhlola okwenziwa ngumuntu onekhono ngokusebenza kwenxazululo ngokwanele ngokuhambisana nezidingo ezibandakanya njengesidingo, inqubo yokuninga, ukubala kanye nokunaka izimiso zokuhlaziya ezivunyiwe, exhasa inhlanganisela yokukhishwayo olwazini olukhona, ucwaningo kanye neminingwane, ukuvivinywa okufanele kanye nesipiliyoni sezinsizakalo

## Isifanekiso esinomqondo (ubunjiniyela bomlilo)

isifanekiso esakhiwe ngumuntu obhaliswe ngokuhambisana Nomthetho Wephrofeshini Yonjiniyela, ka-2000 (Umthetho weNo-46 ka-2000)-(i-*Engineering Profession Act, 2000 (Act No. 46 of 2000)*) Njengonjiniyela Oyiphrofeshinali noma Usochwepheshe Wonjiniyela Oyiphrofeshinali, futhi uthathwa jikelele njengonolwazi oludingekayo kanye nokuqeqeshwa ukuthatha izinhlolo ezinomqondo noma izifanekiso emkhakheni wobunjiniyela bomlilo

**QAPHELA:** Lezi izincazelo jikelele, okumele zisetshenziswe lapho kungekho khona incazelo enikeziwe, noma kungekho amareferensi enziwe maqondana namanye amazanga. Ezinye izingxenye ze-SANS 10400 ziqukethe izincazelo eziwuhlobo olucacile kakhulu ezimaqondana nemikhakha.

## INQUBOYE PHROJEKTHI

### IZIDINGO

Ukwakhiwa kophahla lotshani kanye nezakhiwo ngumsebenzi okhethekile. Nanoma isakhiwo singaba sikhulu noma sincane kanjani. Imithetho ibeka ukuthi isakhiwo noma uhlelo lokuthi isakhiwo sizobukeka kanjani kumele ludwetshwe kuqala futhi isakhiwo sidwetshwe ngumqambizimo noma unjiniyela wezakhiwo. Isifanekiso kumele sihloniphe imithetho kaMasipala Yokwakha Kuzwelonke i-(SANS 10400-L, SANS 10400-T and SANS 10407 (Izincasiselo Zokwakhiwa Kophahla Lotshani).

### ABAOAMBIZIMO KANYE NONJINIYELA

Umqambizimo uzongenisa izinhlelo kumasipala njengomuntu oyedwa oneziqo kanye norejistiwe ne-SACAP, okuyi-*South African Council of Architectural Profession*, angangenisa izinhlelo. Umnikazi wendlu obhalisiwe kuzodingeka ukuba asayine amafomu ahlukile kamasipala anikeza umqambizimo imvume ukuthi babangenisele izinhlelo. Ekungenisweni kwezinhlelo ngazinye kuzodingeka ikhophi yencwadi yokuba ngumnikazi wendlu (*i-property title deed*) njengezidingo eziyisisekelo zokungenisa.

Uhlelo kumele luvunyelwe nguMasipala kanye nonjiniyela wezakhiwo (umuntu onekhono) kumele ahloniphe isakhiwo aphinde ahlole isakhiwo ukuqinisekisa ukuthi siyawalandela yini amazinga kanye nemithetho emva kokuba sesiqediwe. Unjiniyela uzobe esenikeza Isitifiketi Sokuhlonipha se-A19 okusho ukuthi isakhiwo siyawahlonipha wonke amazinga kanye nemithetho. Ngaphandle kwesitifiketi esinje umasipala angake asayine avumele yinona yisiphi isakhiwo ukuze sinikezwe imvume. Umhloli webhilidi naye uzonikeza Isitifiketi Sokuthi Kuqediwe esivela kwaMasipala maqondana nokuqedwa uma zonke izidingo ziye zafinyelelwa. Ibhilidi alikwazi ukuthengwa noma lithengiswe ngaphandle kwalesi sitifiketi.

Ukusebenzisa umuntu onekhono kuphinde futhi kukwenze ukuthi ube nesakhiwo esifanekiselwe yonke imithetho yomlilo emqondweni ezuzisa abanikazi bomuzi uma kumaqondana nomshuwalensi. Uma nje izindlela zokuvikela umlilo ezifanele zikhona, izinkampani zomshuwalensi zibheka amaphrimiyamu loku kuzuzisa umnikazi hhayi ngokwezimali kuphela kodwa kunikeza ukuphumula kwengqondo. Umuntu onekhono, umuntu orejistiwe ngokuhambisana Nomthetho Wephrofeshini Yonjiniyela, ka-2000 (Umthetho WeNo-46 ka-2000), njengoNjiniyela Oyiphrofeshinali noma uNjiniyela

# UMHLAHLANDLELA WOKWAKHIWA KOPHAHLA LOTSHANI ENINGIZIMU AFRIKA

---

Oyiphrofeshini Kwezobuchwepheshe, futhi enolwazi oludingekayo emkhakheni wobunjiniyela bezomlilo, uzophinde ahlinzeke uMasipala Ngesifanekiso Esicatshangiwe esivame ukufunwa ngumnyango wezomlilo ongaphakathi komasipala, ukubonisa izibalo ezehlukile nengozi kumabhilidi aseduzane nalo. Ukuba khona komsebenzi owenziwe kabi, izinga lezinto zokwakha ezisetshenzisiwe kanye nokungabi khona kwezinhlelo ezivunyiwe kanye nokungahlinzeki izitifiketi nezifanekiso ezishiwo ngenhla, kuthelala isimo seMboni. Ukusuka ekusungulweni kwe-TASA ngomhla ka-1 ku-Januwari ka-2006, izimpawu ezimbili ezisemqoka ezatholakala maqondana nempumelelo noma ukwehluleka kwenkampani Eyakha Uphahla Lotshani eziye zavela ngaphambili, okuyilezi:

1. Ukuhlola endaweni yokusebenzela ngumuntu onolwazi
2. Izinga lezinto zokwakha kanye nokwenziwa komsebenzi

Ophahla abakhiwe ngotshani abakhiwe ngaphandle kwezinhlelo ezivunyelwe kanye nangaphandle kokuhlolwa ngunjiniyela oneziqo kubangela amaklayenti kanye ne-TASA ikhanda elibuhlungu. Umsebenzi owenziwe kabi, izinkinga zokwakha kanye nezinto zokwakha ezisezingeni eliphansi ezisetshenzisiwe zihlinzeka ubufakazi obenele kuklayenti ukuze libeke owekontileka icala. Yinoma yiluphi uphahla olwakhiwe ngotshani eNingizimu Afrika kumele lwakhiwe ngokwezidingo zezincasiselo ze-SANS 10407 – 2015 Isihumusho sesi-2 (Ukwakhiwa Kophahla Lotshani) kanye ne-SANS 10400 (Imithetho yokwakha Kuzwelonke ngokubhekisa ngokuqondile engxenye ka-L)

Kungukunaka kweklayenti okukhulu ukuqinisekisa ukuthi zonke izidingo ezishiwo ngenhla ziyafinyelelwa futhi nokuqhubeka abuzwe ukuthi owakha uphahla lotshani urejistiwe njengelungu le-TASA. Ngokuqalisa iphrojekthi Yokwakha Uphahla Lotshani enalesi sisekelo, uqinisekisa umphumela onempumelelo kanye nenqubo engenayo inkinga.

## ABEKONTILEKA BOKWAKHA UPHAHLA LOTSHANI

Ukukhetha owekontileka wokwakha uphahla lotshani yisinyathelo esisemqoka kakhulu kule nqubo. Kusemqoka ukuqinisekisa ukuthi owekontileka urejistiwe ku-TASA, i-*Thatchers Association of South Africa*. Omakhi Bophahla Lotshani abarejisitwe ku-TASA bonke bayazilandela izidingo kanye namazinga ophahla lotshani olusezingeni elifanele. Njengoba kushiwo, imboni yokwakhiwa kophahla lotshani ngumkhakha okhethekile kanye nokukhetha owekontileka obiza kancane kungaba yiphutha elibiza kakhulu elingenziwa ngumnikazi wendawo.

# UMHLAHLANDLELA WOKWAKHIWA KOPHAHLA LOTSHANI ENINGIZIMU AFRIKA

---

Kukhona izimiso eziyisisekelo ezikhethekile maqondana nokwakha uphahla lotshani okumele zihlonishwe. Ukuthola impilonde esemqoka evela ophahleni, izici ezithile, ezingekho sobala ebantwini abangebona osomaciko kumele kulandelwe okufana namagumbi ophahla, izikhundla namagumbi ezigodi ngokuqondana nezinye izici zomqondo wokuqala. Uhlelo lobuphansi kanye nokuphakama kwebhilidi kuthela isifanekiso sesakhiwo sophahla okwenza ukuthi kuthelwe ukuqina kwesakhiwo sophahla ikakhulukazi lapho kukhona ubude bezinkalo kanye nezinhlangano zophahla. Lezi zinhlangano azivumeli ukubekwa kwezibopho ngempumelelo futhi kuvamile ukuthi kungabi khona izindonga zokweseka ukuze zinqophisane ngokungabi khona izibopho ezinempumelelo.

Uma kunikezwa okungenhla, umqambizimo, ngesikhathi sesigaba sokudwetshwa kohlelo, kumele axhumane nesiphathimandla embonini ukulungisa noma ukushintsha isifanekiso eqinisekisa ukuma ngokuqondile kwesakhiwo okungaguquki kanye nokukhuphula izinga lzindawo zokugeleza kwamanzi ngenxa yokwakhiwa kwemiqansa efanele kanye nezindawo zezigodi ngokuhambisana nesifanekiso sophahlajikelele.

Ukuhlaziya isakhiwo sophahla lotshani injiniyela izodinga isifanekiso sesakhiwo sophahla oluphakanyisiwe ukubala ubukhulu bezinsika kanye nenani nedayametha yemishudo edingekayo kuzixhumo ezehlukile.

Kuvame kakhulu kulezi zikhathi zamanje ukuthi ophahla bokwakhiwa ngotshani bakhiwe ngaphandle kokudwetshwa kanye nokuhlaziywa kwezakhiwo futhi njengomphumela, emva kwalelo phuzu, kunzima futhi kubiza kakhulu ukuzishintsha, kwesinye isikhathi akwenzeki nhlobo. Uma kukhona okudwebiwe okufakwe imininingwane ephelele umqambizimo angakwazi futhi ukuhlola okwezinzwa zesakhiwo bese ngokuhlanganyela nonjiniyela aguqule imininingwane ukuze iklayenti lizuze.

## IMIBUZO ESIZAYO UMA UQASHA OWEKONTILEKA

Kungabe Owekontileka:

1. Uyazazi izingcaciso ze-SANS 10407 – 2015 Isihumusho sesi-2
2. Uyayazi imithetho Yokwakha Kuzwelonke
3. Uyilungu Labakha Uphahla Ngotshani baseNingizimu Afrika

# UMHLAHLANDLELA WOKWAKHIWA KOPHAHLA LOTSHANI ENINGIZIMU AFRIKA

---

4. Ithini inombolo yakhe yobulungu
5. Uyirejistele i-VAT
6. Inkampani inesikhathi esingakanani isebenza
7. Unawo amareferensi avela:
  - a. Kubaqambizimo
  - b. Konjiniyela
  - c. Kumaklayenti
8. Unawo amaphrojekthi aqediwe, Iphothifoliyo
9. Unayo ingqalasisizinda edingekayo kanye nabasebenzi abaqeqeshiwe
10. Uzohlinzeka ngekontileka ebhalwe phansi ebonisa ukuvumelana kwamaqembu womabili
11. Uyavuma ukuthi ngubani ozoba nesibophezelo sokuhlinzeka imidwebo yesakhiwo edingekayo, kanye nezinhlelo zokwakha bese ehlela ukuvunyelwa kwazo yiziphathimandla eziqondene nezifanele
12. Uhlelela ukuhlolwa okufunekayo bese uthola ukuphothulwa okufunekayo kanye nezitifiketi zobunjiniyela
13. Uyasho ukuthi ngubani onesibophezelo sokubhekana nomshuwalensi ngesikhathi kwakhiwa
14. Unikeza yinoma yimaphi amagaranti maqonda nomsebenzi owenziwe kanye nezinto zokwakha.

## IMIBUZO ENGABUZWA YIZINKAMPANI ZOMSHUWALENSE

Imibuzo evamile engabuzwa Yinkampani Yomshuwalensi:

- Lithini igama Lenkampani Yakho Yokwakha Uphahla Lotshani?
- Isimo samanje sophahla sinjani?
- Kungabe ibhilidi liye lafakwa izintambo futhi?
- Ukwakhiwa kwezindonga (izitini nodaka lokwakha, nokhuni)?
- Kungabe ikhishi linesilingi engukhonkolo?
- Kungabe ibhilidi linawo yini ushimula?
- Uma ngabe impendulo ngu-YEBO, kungabe ivele ngaphezu komugqa wophahla?
- Kungabe uyayisebenzisa imililo evulekile, ebaselwa ngezibaso eziqinile (isib. ukhuni)?
- Kungabe oshimula bafakwe izibambinhlansi?

# UMHLAHLANDLELA WOKWAKHIWA KOPHAHLA LOTSHANI ENINGIZIMU AFRIKA

---

- Kungabe ibhilidi linokokudlulisa umbani okuvunyelwe?
- Kungabe uphahla olwakhiwe ngotshani liye lahlinzekwa ngohlelo lokuvimbela umlilo?
- Kungabe ibhilidi livikelwe yizinhlelo zokunethisa?
- Kungabe izibambo zethumbu lokulwa nomlilo zifakiwe kuleyo ndawo?
- Kungabe unaso yini Isitifiketi Sokuhlonipha esivela emthonjeni onekhono noma onikezwe iziqu, noma ngakwelinye icala, uma ngabe Unesitifiketi Sobunjiniyela?
- Kungabe ibanga elingakanani ukusuka la ukhona uye Esiteshini Sokucima Umlilo?

## INQUBO EMAQONDANA NEPHROJEKTHI ENEMPUMELELO

1. Ukudwetshwa kwezakhiwo noma uhlelo oludwetshwe Ngumqambizimo/Unjiniyela Wezakhiwo kwase kuvunyelwa yiziphathimandla ezifanele kumele kuhlinzekwe.

(Omasipala asoze banikeza isitifiketi sokuhlala ngaphakathi ngaphandle kwezinhlelo zokwakha ezivunyelwe futhi ukudluliselwa kwendlu egameni lomnikazi angeke kwenzeka uma okungenhla kungekho.)

- 1.1 Ekwezini ikhothi yephrojekthi Owekontileka kumele abe azi kahle ngaloko okulindelwe kuye kanye nazo zonke izincasiselo anikezwe zona ukuze abale wonke amanani.
- 1.2 Owekontileka kumele aqinisekise ukuthi imidwebo noma izifanekiso zihlonipha imithetho ephathelene nokwakhiwa kophahla lotshani.
- 1.3 Owekontileka kumele ahloniphe zonke izidingo/izincasiselo njengoba zibekwe ngunjiniyela wezakhiwo noma umqambizimo ukuze isitifiketi sokugcina semvume sitholwe kubo uma sekuqedwe iphrojekthi.

2. Incasiselo

Ukwakha kumele kuhloniphe izidingo ze-SANS 10407 – 2015 Isihumusho sesi-2

3. Ikontileka Ebhalwe Phansi

Ikontileka evunyiwe yaphinde yasayinwa ngamaqembu omabili ingokudingekayo ngaphambi kokuba kuqaliswe iphrojekthi.



# UMHLAHLANDLELA WOKWAKHIWA KOPHAHLA LOTSHANI ENINGIZIMU AFRIKA

---

4. Izikhalazo kanye Nokuxhumana
  - 4.1 Ukuxhumana okwakhayo nokwenzeka njalo ngaphakathi kwabo bobabili Iklayenti kanye Nowekontileka kuyagqugquzelwa.
  - 4.2 Imibhalo efanele, egcwaliswe ngemfanelo kanye necacile ngokuphathelene nezicelo kanye nokulungiswa kusemqoka kakhulu kuyo yonke iphrojekthi ukugwema ukungaqondisisani.

## IZIBOPHEZELO ZOWEKONTILEKA

1. Ukunikezwa izimpendulo ngaso sonke isikhathi ngesikhathi umsebenzi uqhubeka.
2. Amaklayenti kumele aziwe ngokuphelele ngomsebenzi okumele wenziwe kanye nezincasiselo kanye nezidingo zomthetho.
3. Amaklayenti kumele ahlinzekwe ngombhalo ofakwe imininingwane obonisa intengo kanye nezidingo zenkokhelo. Loku kubandakanya amakhotheshini alinganiselwe nabhalwe phansi.
4. Amaklayenti kumele futhi ahlinzekwe ngemininingwane yesikhathi esilinganiselwe efakwe ulwazi lonke kanye nosuku okulindelwe ukuthi umsebenzi uphele ngalo. Uhlelo lwesikhathi oluphelele kumele luhlinzekwe.
5. Amaklayenti kumele aziswe ngaso sonke isikhathi nganoma yiziphi izinguquko ezingathelela usuku lokuqeda oluphakanyisiwe bese befakela ulwazi ohlelweni lwesikhathi ngokufanele.
6. Owekontileka kumele avume isibophezelo sezenzo zabasebenzi bakhe/abaqashiwe okubandakanya amakontileka amancane, abeluleki noma amajenti aqashwe nguye.

## IZIBOPHEZELO ZEKLAYENTI

1. Iklayenti kumele lifune zonke izimvume ezifanele kuziphathimandla ukugwema ukuchitheka kwesikhathi.
2. Izinkokhelo ezibekelwe isikhathi esiqhubekayo kanye nenkokhelo yokucina okuvunyelwene ngayo.
3. Ukubumbana kanye nokusiza njengoba kudingeka.

## IZIFANEKISO ZOPHAHLA LOTSHANI

Amalungu Enhlangano Yabakhi Bophahla Lotshani yaseNingizimu Afrika bakhe izifanekiso eziwubuciko ezehlukile futhi baveze ngokusobala ukuthi uphahla lotshani lungaba okuningi nokungaphezulu kunezifanekiso zosiko. Lezi ezilandelayo ngezimbalwa kuphela eziyizibonelo.



Uphahla Lotshani lokokwakha okwakiwe okwethula izinzwa



Qaphela Imijibe Egotshiwe

# UMHLAHLANDLELA WOKWAKHIWA KOPHAHLA LOTSHANI ENINGIZIMU AFRIKA

---



Ukwembozwa  
Kwezintingo  
ezindongeni zegebhula.



Izindlela eziwubuciko  
nezigqwalile zokufihla  
imishudo namanati.

# UMHLAHLANDLELA WOKWAKHIWA KOPHAHLA LOTSHANI ENINGIZIMU AFRIKA

---



Ihhotela  
Lophahla  
Olwakhiwe  
Ngotshani



Uphahla  
olwakhiwe  
ngotshani  
oluqedelwe  
ngokugqwalile



Isakhiwo  
esimangalisayo  
ebholidini  
eligotshiwe  
eliqedelwe  
ngobuhle  
obukhulu.

## OKOKWAKHA UPHAHLA LOTSHANI

### UTSHANI BOKWAKHA UPHAHLA NEZINTUNGA JIKELELE

Endaweni eseNtshonalanga Kapa kwakha izakhiwo Zephayini yaseNingizimu Afrika ezenziwayo bese kuthi eNingizimu Afrika yonke izakhiwo zakhiwe nge-*Blue Gum/Eucalyptus*.

Utshani baseNingizimu Afrika obuvame ukusetshenziswa, kanye namagama abo, nezindawo zezezwe kwenziwe uhlu lapha ngezansi:

- *I-Hyparrhenia hirta* (baziwa jikelele njengotshani obuvamile bokwakha uphahla lotshani) – bugcwele kakhulu; endaweni yase-Natal Berg;
- *I-Hyperphilia dissoluta* (baziwa ngokuvamile njengotshani bophahla obuluphuzi) – butholakala eSifundazweni EsiseNyakatho, e-Mpumalanga, e-Nyakatho ye-KwaZulu-Natali kanye naseSwazini;
- *I-Thamnochortus insignis* (noma utshani bophahla baseKapa, obaziwa ngokuvamile njenge- “*dekriet*”,) – e-*Albertinia* nakumaDistriki ase-*Riversdale* ase-Kapa;
- *I-Hyparrhenia dregeana* – e-Natal Midlands nasendaweni yase-Berg;
- *I-Hyparrhenia filipendula* (baziwa ngokuvamile njengotshani bokwakha uphahla obucolisakele) - KwaZulu-Natali, nasezifundeni ezingasogwini lwe-Zululand;
- *I-Thamnochortus erectus* ne-*Thamnochortus specigerus* (i-*dekriet* noma intunga yophahla lotshani) – Ezifundeni Ezisogwini lwaseKapa;
- *I-Chondropetalum tectorum* – Igcwele kakhulu endaweni yase-Kapa; (Abuphakanyiswa)
- *I-Phragmites australis* (intunga ye-*Norfolk* noma utshani obumila ezindaweni ezimanzi, obaziwa ngokwendawo njengotshani Umhlanga) – obugcwele yonke indawo eNingizimu Afrika. (Abuphakanyiswa)

**QAPHELA:** Kusemqoka ukuthi usebenzise utshani bophahla obumila kuleyo ndawo okuyo, ngaphandle uma kulezo zindawo, utshani bokwakha uphahla bungamili.

## UMHLAHLANDLELA WOKWAKHIWA KOPHAHLA LOTSHANI ENINGIZIMU AFRIKA

---

Okokwenza kokwakha uphahla lotshani, ngaphandle uma kucaciswe ngenye indlela, kumele kuhloniphe uhlu lwezinhlobo zotshani kanye nezintunga ezivamise ukusetshenziswa eNingizimu Afrika kanye nasezindaweni zayo zezezwe.

Loku kusho ukuthi utshani bophahla kumele kube ngobohlobo obunomlando wokusetshenziswa ngempumelelo njengesembozo sophahla ezindaweni zezezwe ezifanele futhi kumele buvunwe ngesikhathi ukukhula sekumile, noma uhlamvu seluvuthiwe lwaphinde lwasabalaliswa.

Yinoma yikuphi okusetshenziswayo kotshani lophahla kanye nazo zonke izinhlelo zokuvimbela umlilo, akumele kuthelwe ubude bempilo bokokwenza bokwakha uphahla lotshani, noma buguqule uhlobo lokokwenza ngaphambi kwesikhathi.

Utshani bophahla kumele bugcinwe ngendlela yokuthi kungabi khona ukulimala kwendawo eyisiqu, ukusuka ngokucacile endaweni ephansi futhi nokungavezwi ngokungena sizathu esimweni sezulu.

# UMHLAHLANDLELA WOKWAKHIWA KOPHAHLA LOTSHANI ENINGIZIMU AFRIKA

---

## INCASISELO YOTSHANI BOKWENZA UPHAHLA

Utshani obuvamile noma obucolisekile bokwakha uphahla (*i-Hyperrhenia Hirta* kanye ne-*Hyperrhenia Phillependula*) ukuze busetshenziswe kumele:

1. Bube nobude bokusikwa obungekho ngaphansi kuka-0,8m (uma bulinganiswa ukusuka esidunwini kanye nobubandakanya izinhloko zezidunu zezinhlamvu)

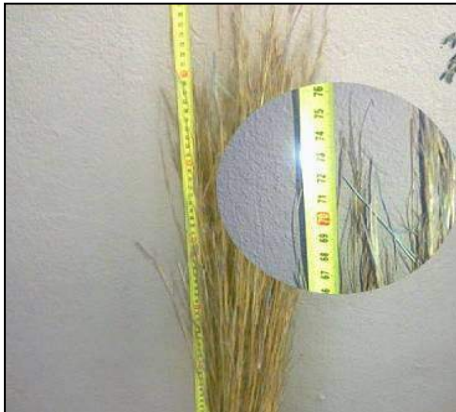

Ubude obusikiwe obungafanele obungu-0.75m



Ubude obusikiwe obufanele obuwubude obungaphezu kuka-0.8m

2. Kumele bube nedayametha ewubuncane nedayametha engubukhulu esiphethweni esiyisidunu esingama-1,2mm kanye nama-2,5mm ngokuhambisanayo;



Idayametha engafanele esiphethweni esiyisidunu: okungu-1mm.

# UMHLAHLANDLELA WOKWAKHIWA KOPHAHLA LOTSHANI ENINGIZIMU AFRIKA

---



Idayametha efanele esiphethweni esiyisidunu ngaphakathi kuka-1.2mm no-2.5mm.

3. Bube ngobuvunyelwe obuqondile (obusikwe ngaphezu kwenodi yokuqala);



Obusikwe ngokungafanele ngaphezu kwenodi yokuqala, bheka utshani bophahla obugobile. Lobu buzokhiqiza indawo engaqediwe ngaphezulu phandle ophahleni lwakho.



Obusikwe ngemfanelo ngaphezu kwenodi yokuqala



# UMHLAHLANDLELA WOKWAKHIWA KOPHAHLA LOTSHANI ENINGIZIMU AFRIKA

---

4. Bukhululeke maqondana nokokwakha okukhumukayo;



Utshani bophahla obubi obungakanyiwe ngenkathi buvunwa buqethe okokwenza okukhumukayo



Utshani bophahla obuvunwe ngokufanele obungenako okokwenza okukhumukayo

5. Akumele kube sesikhathi sonyaka sokutshala;

6. Kumele bungabi nawo amakhanda ayizinhlamvu uma busikwa.



Isampuli iqukethe amakhanda anezinhlamvu emva kokusikwa

# UMHLAHLANDLELA WOKWAKHIWA KOPHAHLA LOTSHANI ENINGIZIMU AFRIKA

---



Isampula engenawo amakhanda anezinhlamvu ngesikhathi sokuvuna

## INCASISELO YENTUNGA YASEKAPA

Intunga yokwakha uphala lotshani (*i-Thamnochortus species*) ukuze isetshenziswe kumele:

1. ibe nobude obusikiwe obuwubuncane obungama-1,0 m (obulinganiswe ukusuka esiphethweni sesidunu kanye nokuhlinzekwe ngezihloko zesiphetho sesidunu sezinhlamvu)
2. kumele ibe nedayamtha ewubuncane obungu-1,2 mm kanye nedayametha ewubukhulu obungama-5 mm esiphethweni esiyisidunu;
3. kumele ibe ngeqondile ngokuvunyelweyo;

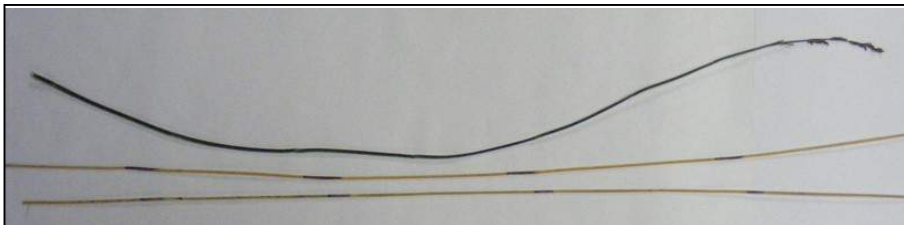

Isampuli ayiqondile ngokuvunyelwe

4. ikwazi ukusebenzeka;
5. ingasikwa ngesikhathi sonyaka sokutshala (ukuqinisekisa ukuthi amanodi aqinile);



Lesi silayidi sibonisa ukuthi le ntunga isikwe ngesikhathi sonyaka sokutshala (ngakho-ke amanodi akhumukile)



Amanodi aqinile asikwe ngesikhathi sonyaka sokutshala (Ngakho-ke amanodi aqinile)

## UMHLAHLANDLELA WOKWAKHIWA KOPHAHLA LOTSHANI ENINGIZIMU AFRIKA

---

6. ibe ngekhulile nenokhuni;
7. ingabi nawo usawoti kanye nodaka noma isihlabathi;
8. yomiswe elangeni okungenani izinsuku eziyi-7 ngaphambi kokwenziwa izinkatha.



Indlela engafanele yokubeka intunga yase-Kapa  
Igcwele izinhlamvu kanye namaqabunga



Umehluko ezingeni lentunga  
Ukuguquka kombala wentunga engakhulile  
ngokuphelele

### INCASISELO YENTUNGA YASEMANZINI

Intunga yasemanzini (i-*Phragmites australis* noma *Phragmites communis*) okumele isetshenziswa kumele:

1. inobude obuwubuncane kanye nobude obuwubukhulu buka-1,5 m no-1,8 m, ngokuhambisanayo (ilinganiswa ukusuka esiphethweni esiyisidunu futhi ibandakanya izihloko zeziphetho eziyisidunu zezinhlamvu)

### UKUGCINWA KOTSHANI BOKWENZA UPHAHLA

#### ENDAWENI YOKUSEBENZELA

Okokwakha uphahla lotshani kumele kugcinwe ukuze:

1. indawo eyisiqu ingalimali ngokwesimo,
2. izinkatha zisuswe endaweni ephansi,
3. izinkatha zingavezwa ngokungacatshangiwe maqondana nomswakamo kanye nelanga.

## UMHLAHLANDLELA WOKWAKHIWA KOPHAHLA LOTSHANI ENINGIZIMU AFRIKA

---



Ukugcinwa okungafanele kotshani bokwakha  
uphahla lotshani endaweni yokusebenzela



Ukugcinwa ngemfanelo kotshani bokwakha  
uphahla endaweni yokusebenzela



Intunga yaseKapa yezinga elihle eyenziwe inqwaba  
ngemfanelo

# UMHLAHLANDLELA WOKWAKHIWA KOPHAHLA LOTSHANI ENINGIZIMU AFRIKA

---

## UKUHLANZA NOKUBEKWA NGEZINYANDA

Emva kokuthi utshani sebusikiwe benziwa izinyanda ezingahlangene, inyanda ngayinye iyathintithwa ngamandla amakhulu ukuze kuthintitheke konke okokwakha okungaqinile. Izinyanda ziyahlanzwa—ke ngokudlulisa isikela ngaphakathi kwazo, kusetshenzwa ukusuka phezulu ukuya phansi. Izinyanda zotshani zingaphakathi kwedayametha engama-75 nama-100 mm. Lezi zinyanda ziboshwa zibe yinyanda ngayinye ngomchilo wotshani obusontiwe noma ngentanjana bese bubekwa buba yizinqwaba.

Izinqwaba zotshani bophahla ziyidayametha ecishe ibe ngama-75mm, ziboshwe ngentanjana bese zibekwa ziqonde phezulu.

## ISAKHIWOSOPHAHLA

### UKUBEKWA KWESIMO SESAKHIWO

Uma izinsika zimiswa kusemqoka ukuthi kuqinisekiswa ukuthi amagumbi ame abangu-90 deg. Indlela elula yokuqinisekisa loku ukusebenzisa ubukhulu obuboniswe emdwebeni ongezansi ukuqinisekisa igumbi elilungile elingu-90 deg.

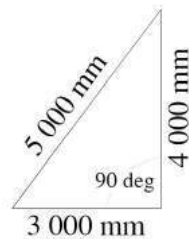

Kulula kakhulu ukudweba ukuma kwenqulu kanye nomjibe wakho endaweni yokusebenzela usebenzisa umugqa wakho wendawo yangaphakathi webhilidi endaweni ephansi bese uphawula zonke izikhundla zezinsika kulo mugqa wendawo ephakathi bese uphawula ngokufanayo ezindongeni.

$$A = 6,100 \div 2 = B \ 3,050$$

Isikhundla senqulu = C 3,050 (ifana no-B 3,050)

u-D 7,800 uyisamba sebanga ngaphakathi nezikhundla zezinqulu.

Ukubala isikhala somjibe u-D  $7,800 \div 900\text{mm}$  (isikhala somjibe esiwubukhulu) = 8,666 izikhala ngaphakathi nemijibe. (Njalo nje singaphansi kodwa akumele sibe ngaphezu kuka-900mm),

Ngakho-ke u-D  $7,800 \div 9$  izikhala = E 866mm wezikhala zemijibe.

Insika kanye notshani obomile kubalwa ukuthi kungabi ngaphezu kuka-2,700 kulesi sehlakalo kungu-F 2,600.

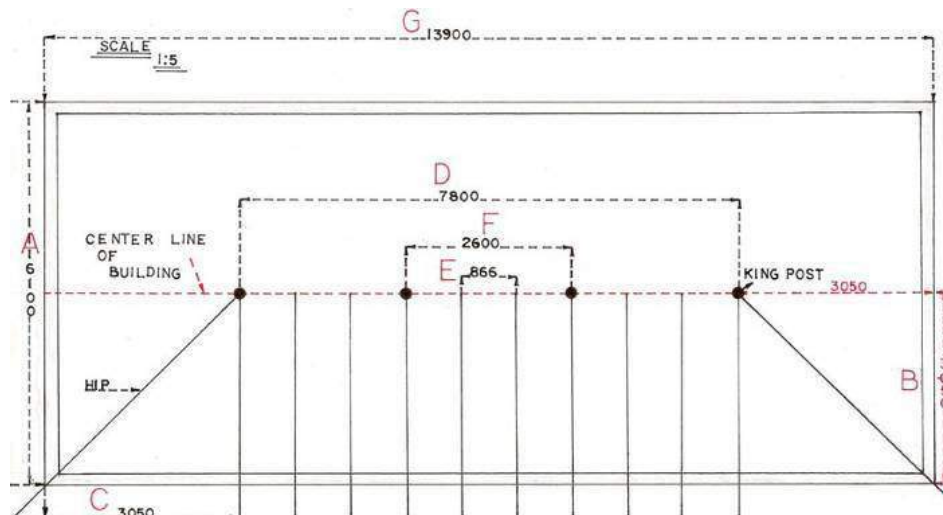

# UMHLAHLANDLELA WOKWAKHIWA KOPHAHLA LOTSHANI ENINGIZIMU AFRIKA

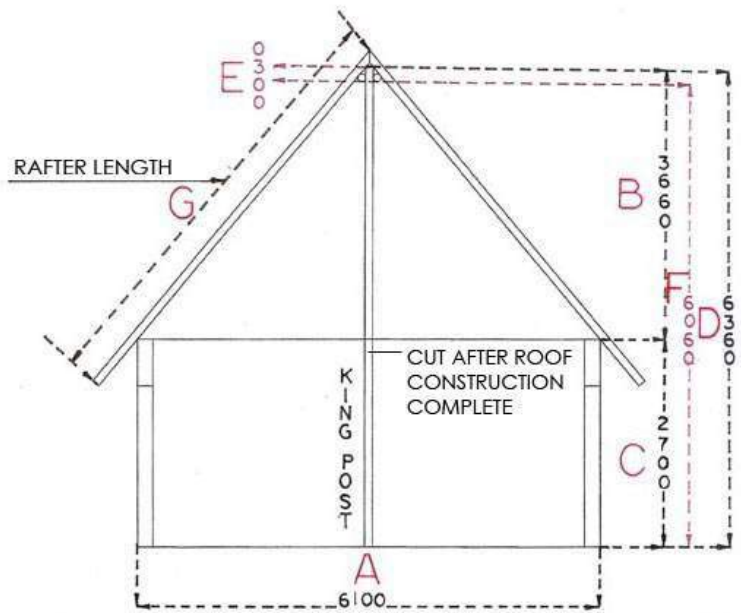

- |   |   |                                     |
|---|---|-------------------------------------|
| Centre line of building                 | - | Umugqa ophakathi nendawo webhilidi  |
| A. King post                            | - | Insika                              |
| G. Rafter length                        | - | Ubude bomjibe                       |
| A. Cut after roof construction complete | - | Kusike emuva<br>kokwakhiwa kophahla |

Uphahla olwakhiwe ngotshani kumele lube nokuphakama okuwubuncane obungama-45°. Ummango ongumqansa uyadingeka ukuze amanzi ageleze ahambe ukusuka endaweni ewuphahla ngokungena ngaphakathi komzimba wekhoti yophahla lotshani. Ekuphakameni okungaphansi kwama-45° uphahla lotshani luzobola ngokushesha. Okuhle kungenziwa maqondana nokuphakama okuwumqansa ukusebenzisa isikhala sophahla sibe yigumbi elingeziwe.

Ukubala ubude bokuphakama bophahla izimpawu ezingenhla zingasetshenziswe kuye ngokwegumbi lophahla. A = ububanzi, B = ubude, C = uphawu lokubala ubude bokuphakama

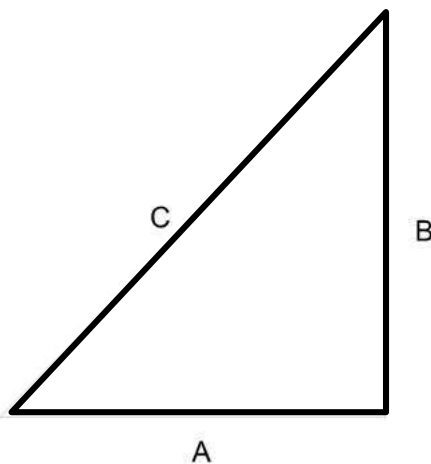

IGUMBI	A	B	C
35 deg	1.000	0.700	1.221
40 deg	1.000	0.839	1.305
45 deg	1.000	1.000	1.414
50 deg	1.000	1.192	1.556
55 deg	1.000	1.428	1.743
60 deg	1.000	1.732	2.000

# UMHLAHLANDLELA WOKWAKHIWA KOPHAHLA LOTSHANI ENINGIZIMU AFRIKA

---

Le nkinga ivamise ukubangelwa wukuhlela okungafanele kanye nokuswela ulwazi. Uma ngabe ubude obufanele bamapholi bungabalwa ngemfanelo, indlela emfushane izokwenziwa, okusho ukuthi ukwehlisa ubude ukulinganisela imijibe emifushane. Lezi zandisi kuphakama zingathengwa kunoma yisiphi isitolo esithengiswa izinto zokwakha futhi azimbi eqolo.



Ukuphakama Kophahla Okungafanele okungaphansi kuka-45° odingekayo



Ukuphakama Kokuqala Kophahla Okufanele okungama-45° noma ngaphezulu



Ukuphakama kophahla lotshani okungafanele.



Ukuphakama kophahla lotshani okufanele.



# UMHLAHLANDLELA WOKWAKHIWA KOPHAHLA LOTSHANI ENINGIZIMU AFRIKA

---

## IZIDINGO ZAMAPULANGWE

Amapholi okhuni kumele ahloniphe izidingo ze-SANS 457-2 noma i-SANS 457-3, njengefanele. Amalathi nezikhonkwane kuzohlonipha izidingo ze-SANS 1288, 1707-2 (i-*eucalyptus*), noma i-SANS 1783-4 (iphayini), njengezifanele. Zonke izinkuni kumele zilondolozwe ziphathwe ngokuhambisana nezidingo ze-SANS 10005.

Amapholi asetshenziswa njengezimpawu zesakhiwo kumele abe nedayamitha okungenani engama-100 mm elinganiswa nezidunu ezondile.

## IZINSIKA ZOKUTSHALA

Isayensi yokubheka izinkuni ngemfanelo ihlinzeka ukuthi ukulondolozwa kufakelwe kakhulu ngobunzulu ngaphakathi kwe-*sapwood* ngalokho banikeze ukuwengamela okunzulu kokulashwa ngokuzungelezela indawo ephakathi ye-*heartwood*.

Kuthandeka ukuthi ukhuni lwakho olubhekelayo luthengwe ngobukhulu ozimisele ukulusebenzisa bukulo. Uma kungenjalo bese kufuneka ukuthi usike ukhuni, kungenzeka uveze i-*heartwood* yokhuni engabhekelwanga esimweni esingesihle.

Kusemqoka ukuthi uma ufuna ukugcina ubuqotho bokubhekela usule ngokuzikhandla noma ubhrashe okokulondoloza okufanele isib. I-*Creosote* noma i-*CCA*, ngaphakathi kwendawo esikiwe. Indawo esikiwe yepholi noma ipulangwe akumele kube yindawo oyifaka endaweni ephansi. Ungamane usebenzise le enye indawo engasikiwe. Amapuleti alwisana nokuqhekeka kumele afakelwe kabusha uma usika indawo esemuva yepholi.

Uma ngabe ukhuni, ngokwesibonelo, insika ebhekelelwe imbelwa endaweni ephansi kusemqoka ukuthi uvumele ukudonswa kwamanzi emvula ngokuhambisa ngaphakathi kokhuni.

Yinoma yiliphi ipholi eligujelwe endaweni ephansi kumele libe yinani eliwubuncane lokuhlukaniswa elingu-H4. Uma ngabe ipholi elibhekelwe ligujelwa endaweni ephansi, kusemqoka ukuthi kubhekwe ukukhishwa kwamanzi emvula.

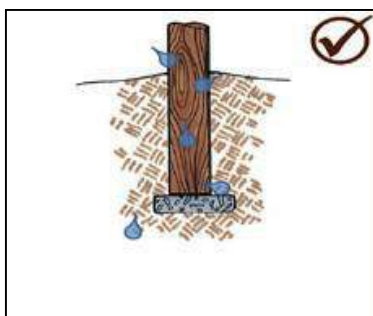

ISIZA/UKUMA: Uma ngabe ipholi limbelwe phezu kwesisekelo esiwukhonkolo qinisekisa ukuthi isisekelo some ngokuphelele ngaphambi kokuba ipholi lembelwe.

# UMHLAHLANDLELA WOKWAKHIWA KOPHAHLA LOTSHANI ENINGIZIMU AFRIKA

---

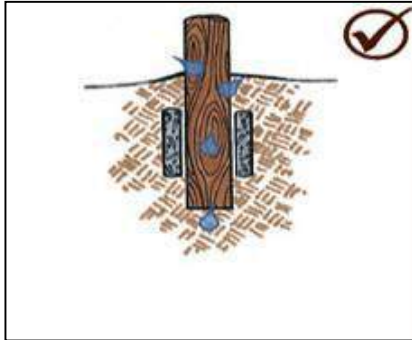

**IKHOLA:** Uma ngabe ukhonkolo usetshenziswa vumela ukuthi ukhonkolo wakhe ikhola nepholi elivele phansi ukuvumela ukuthi umswakamo udonseke.

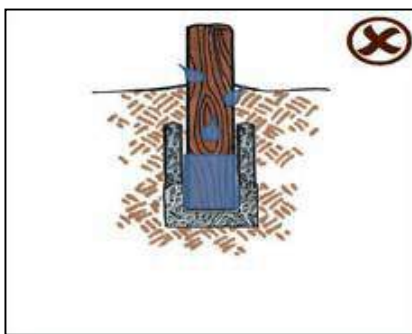

**INKOMISHI:** Ungavumeli ukuthi ipholi lime ngokusondelana phansi nesisekelo sokhonkolo ngoba lizobola ngaphakathi komswakamo ongakwazi ukudonswa.

Imininingwane etholakala kule midwebo engenhla isiza ngokudonswa okufanele kwanoma yimuphi umswakamo okhululekile okungenzeka udonswe yipholi lokhuni. Unjiniyela wesakhiwo kumele kuxhunywane naye maqondana nezidingo zesakhiwo ezinemininingwane ekumbelweni kwamapholi.

Ungafaki isidunu esitshaliwe sensika kukhonkolo. Uma udinga ukusebenzisa ukhonkolo qala ngokulindela ukuthi ukhonkolo wakhe ikhola ukuzungeleza insika bese isidunu sensika sihlole ukuphuma kukhonkolo.

Uma utshala insika kukhonkolo endaweni ephansi yomgodi, vumela ukhonkolo wome ngaphambi kokuba wembele insika.

Ukusebenzisa kanye nokusetshenziswa kokhuni olwelashwe ngokulondolozwa lwekilasi ka-H kuzokunikeza iminyaka eminingi yensizakalo ezokwanelisa ezokululwa futhi ukugcina kusesimweni esifanele.

# UMHLAHLANDLELA WOKWAKHIWA KOPHAHLA LOTSHANI ENINGIZIMU AFRIKA

## AMAKHOLOMU AME AQONDA

Amakholumu ame aqonda kumele anikezwe isikhala esingekho ngaphezu kuka-3.5 wamamitha okuhlukana futhi akumele abe ngaphansi kuka-175 mm (idayametha ephazulu) noma njengoba icaciswe Ngunjiniyela Wezakhiwo.

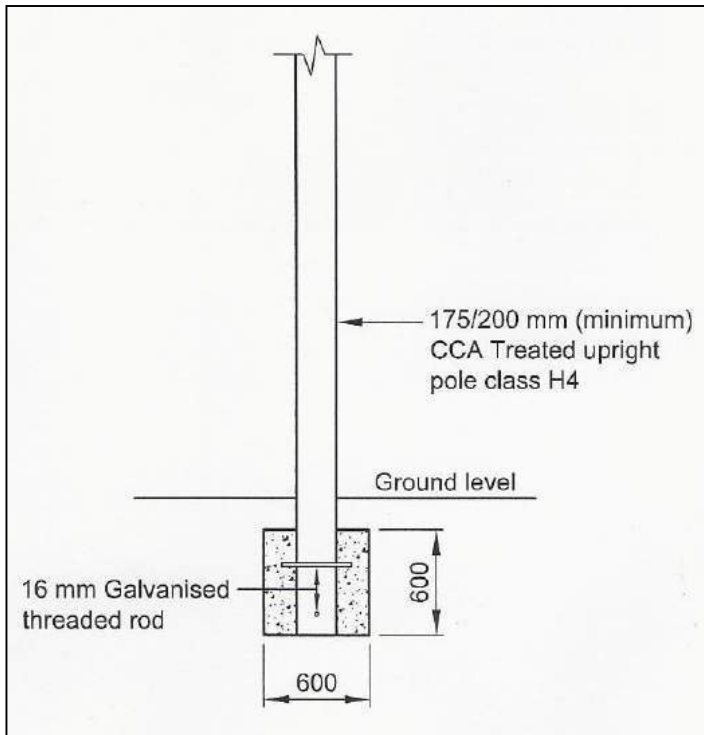

(Ipholi Eliqondile Elibhekwe le-CCA  
lekilasi ka-H4 (eliwubuncane)  
obungu - 175/200mm  
Ground level – Ileveli yendawo  
ephansi  
16 mm Galvanised threaded rod  
- Irodi eliyintambo eyembozwe  
ngensimbi elingu-16 mm

## IZINSIKA

Zonke izinsika kumele zibe nama-*plumb bobs* axhunywe phezulu ngaso sonke isikhathi sokwakha. Loku kuzobangela ophahla olutshekile.



Isikhundla esifanele se-*plumb bob*.

## UMHLAHLANDLELA WOKWAKHIWA KOPHAHLA LOTSHANI ENINGIZIMU AFRIKA

---



Isikhundla esingafanele se-*plum bob*.

Okume kwaqonda akumele kube nezikhala ezingaphezu kwamamitha angama-3.500 okuhlukana kanye nobuhlonzi obuwubuncane bogongolo lokubopha olusandandatho obungekho ngaphansi kuka-150mm Ø ngaphezu kwanoma yiliphi ibhilidi. Ngenkathi kukhuphuka ububanzi bogongolo lokubopha olusandandatho ubuhlonzi buzokhuphuka (kweyeme ekuvunyweni ngunjiniyela).

Amapholi asetshenziswa njengemijibe azokuba nedayametha okungenani engama-100 mm elinganiswa endaweni eyondile yesidunu sepholi.

# UMHLAHLANDLELA WOKWAKHIWA KOPHAHLA LOTSHANI ENINGIZIMU AFRIKA

---

## ISIKHALA SOMJIBE



800 mm

Isikhala esifanele somjibe, esiwubukhulu obungama-900mm ukusuka endaweni ephakathi ukuya kwenye



1 000 mm

Isikhala esingafanele somjibe, sibonisa okungaphezu kokuvunyelwe kwezindawo eziphakathi ezingama-900 mm.

## ISIKHALA SOTSHANI OBOMILE



Ugongolo Wokubopha Osandandatho  
Waphakathi Naphakathi

Utshani obomile obunikezwe izikhala ngokufanele ezingekho ngaphakathi kokuhlukana kuka-2.700m.

# UMHLAHLANDLELA WOKWAKHIWA KOPHAHLA LOTSHANI ENINGIZIMU AFRIKA

## IZIKHALA ZOGONGOLO LOKUBOPHA NOKUBEKWA ESIKHUNDLENI



Isipeni sikhulu kakhulu, sibonisa ukuphambukisa epholini lokhalo

Izikhala ezingenele sampela zogongolo lokubopha kanye nokubekwa sikhundleni. Ngugongolo wokubopha owodwa kuphela obonakalayo futhi azikho izinsika.



Izinsika kanye nogongolo lokubopha okufanele.

## OKUHLANGANISWE NGOGONGOLO OLUSANDANDATHO

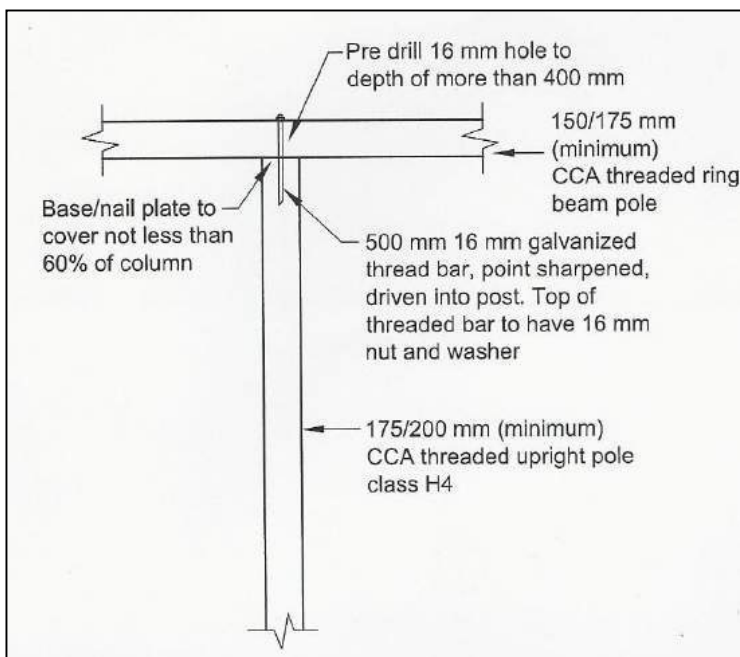

# UMHLAHLANDLELA WOKWAKHIWA KOPHAHLA LOTSHANI ENINGIZIMU AFRIKA

---

Kukhona ukwehluleka okuningi kongongolo olusandandatho futhi kukhona izizathu zaloku ezi-3 ezisemqoka:

1. Ubukhulu bogongolo lotshani olusandandatho buncane kakhulu.
2. Okumiswe kwaqonda kubekwe kwahlukana kakhulu. (Lapho kuphumeleleka khona hlela izinkatha zotshani ngaphezulu kokumiswe kwaqonda).
3. Akukho zigongolo zotshani ezikhona okubangela umthelela wamandla ensinde angeziwe phezu kogongolo lotshani olusandandatho.



Sibonisa isibonelo semishudo nokuxhunywa Kogongolo Lotshani Olusandandatho maqondana nokumiswe kwaqonda.



Ukuxhunywa kogongolo lokubopha lotshani okungafanele maqondana nokumiswe kwaqonda. Qaphela kusetshenziswa kuphela izipikili!



Kuboniswa ukumiswa okuqondile okwengeziwe, okweseka ugongolo lotshani lokubopha olusandandatho oluphansi.

# UMHLAHLANDLELA WOKWAKHIWA KOPHAHLA LOTSHANI ENINGIZIMU AFRIKA

---



Sibonisa ukuxhunywa okubi kogongolo lokubopha ngotshani kokumiswe kwaqonda.

Ubuhlonzi bogongolo lokubopha ngotshani obusandandatho akumele bube ngaphansi kwedayametha engama-150mm elinganiselwa endaweni eyisiphetho eyondile yepholi. Uma nje ibhilidi liloku landa ngobubanzi ubuhlonzi bogongolo bokubopha botshani buzokwanda nabo (kuye ngokwesifanekiso sikanjiniyela)

## UKUPHAMBUKISA



Ugongolo lokubopha ngotshani olunokuphambukiswa.



Ugongolo lokubopha ngotshani olungenako ukuphambukiswa.



# UMHLAHLANDLELA WOKWAKHIWA KOPHAHLA LOTSHANI ENINGIZIMU AFRIKA

---



Ayibonisi ukuphambukiswa epholini eliyi-14m.  
Izipeni ezinde ngesikhathi sokwakha kumele  
zisekwe ukugwema ukuphambukiswa.



Ukuphambukiswa

Sibonisa ukuphambukiswa. Okubangelwa  
ngamapholi ondile kanye nokugitshezwa  
ngaphambi kokuba ogongolo bokubopha botshani  
benziwe.

## IZIBOPHO ZOKUVIKELA UMOYA



Isibopho Sokuvikela Umoya

Ibonisa ogongolo botshani abeseka isibopho  
zokuvikela umoya wehlangothi elingaphansi  
lamapholi emijibe.

# UMHLAHLANDLELA WOKWAKHIWA KOPHAHLA LOTSHANI ENINGIZIMU AFRIKA



Isakhiwo sophahla esiwile ngenxa yokuthi singekho isibopho sokuvikela umoya.

## IZIKHONKWANE NAMALATHI

Izikhonkwane namalathi kuzoqhubeka ngaphezu kokungenani kumijibe emithathu (okusho ukuthi, isikhala semijibe emibili) futhi zizoxhunywa phezu komunye nomunye umjibe eziweqayo. Izikhonkwane zizawushayelwa phezu kwemijibe ngezipikili zocingo ezingama-75 noma ama-100 mm. Kumele kunakekelwe ukuthi kungahlukaniswa yinoma yiliphi lamalunga ngesikhathi senqubo yokushayela.

Izidunu zezikhonkwane zizokuthungwa ngokwesikwele kuhlukaniswa izidunu kumnyombo ngaphezu kwelunga lomjibe. Izinhlango ngaphakathi kwezikhonkwane zizohlelwa ukuthi kungabikho isikhonkwane esingaphezu kwesisodwa kwezintathu esihlangukiswa nanoma yimuphi umjibe owodwa.

Izikhonkwane kanye namalathi okusetshenzisiwe kuzakuba namadayemitha awubuncane obungama-38x38 mm kanye nama-25mm (kudayametha ephezulu) ngokuhambisanayo bese kwenziwa isikhala ngokuhambisana nezidingo zezinhlobo zokwakha uphahla lotshani ezisetshenzisiwe.

## IZIKHALA ZAMALATHI

Amalathi	Ubude bentunga noma utshani bophahla mm	Iminyombo yamalathi Ewubuningi mm
Ilathi lokuqala elivela esikhonkwaneni	-	200
Ilathi lesibili elivela esikhonkwaneni	-	150
Elesibili ukusuka phezulu	-	150
Zonke ezinye izikhonkwane	800, 1 200, 1 500	200, 300, 350
Isikhungo esiwumnyombo sezikhonkwane esiwubukhulu sitholakala ngokuhlukanisa ubude botshani bophahla ngo-4. Izipikili zizakuba nedayametha ewubuncane obungama-2.8 mm		

# UMHLAHLANDLELA WOKWAKHIWA KOPHAHLA LOTSHANI ENINGIZIMU AFRIKA

---



Njengoba kubekwe ethebhulini elingenhla.



Izikhala zamalathi ezingafanele ngoba zedlula umkhawulo owubukhulu obekiwe njengoba kuboniswe ethebhulini elingenhla, sibonisa futhi ukuqedelwa kokwakhiwa kophahla lotshani okwenziwe budedengu.

## IZIGODI

Izigodi zophahla lotshani zizokwakhiwa ngokujwayeza kancane kancane inkatha ngayinye yotshani bophahla engqimbeni ngayinye ukusuka ekumisweni okujwayelekile kokuqondiswa kwenkombandlela ukuya kuleyo elinganisebne nesigodi. Okokwakha okwengeziwe kuzokubekwa esigodini ukuhlinzeka ubuhlonzi obengeziwe ukuvimbela ukungena kwamanzi ngaphakathi kwengqimba yophahla lotshani kanye nokuhlinzeka ukujika kancane kunokuhamba ejikeni elicijile.

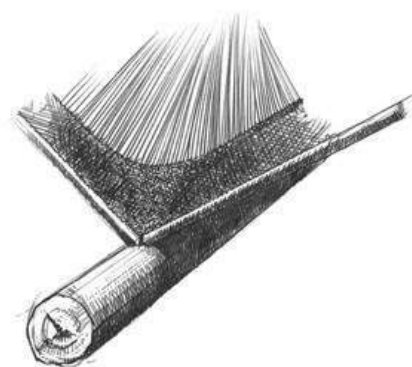

Isigaba esidlula ngaphakathi kwesigodi sotshani esibonisa ukuba luhlonzi kwengqimba yokwakha uphahla lotshani ngaphezu kwesigodi.

## UMHLAHLANDLELA WOKWAKHIWA KOPHAHLA LOTSHANI ENINGIZIMU AFRIKA

---

Izimfoloma zesigodi zivumelekile kusetshenziswa ucecevu olwembozwe ngensimbi (okungafanele intunga yaseKapa), ucecevu lwe-aluminiyamu, izimfoloma zesigodi zethusi noma zebrasi zivumelekile. Ubuhlonzi balezi zinto zokwakha akumelanga zibe ngaphansi kuka-:

- 0.4 mm kucecevu lwethusi
- 0.5 mm kucecevu olwemboze ngensimbi
- 0.7 mm kucecevu lwe-aluminiyamu



Izigodi yizona zokuqala ezimoshekayo kunoma yiluphi uphahla olwakhiwe ngotshani.



Imfoloma yesigodi ifakwa esigodini esimoshekayo.



Imfoloma yesigodi esiqediwe ukufakwa.

# UMHLAHLANDLELA WOKWAKHIWA KOPHAHLA LOTSHANI ENINGIZIMU AFRIKA

---

## IZINQULU

Kumele kunakekelwe uma kwakhiwa uphahla lotshani ezinqulwini ukuqinisekisa ukuthi izinyanda zotshani ekupheleni kokuzinza kwenqulu zigijima ngokulinganisene nomjibe wenqulu. Ngasecaleni ngalinye lenqulu, uma ikhosi iqhubeka isuka kuyo, izinyanda ziyajwayezwa kancane kancane kuze kube yilapho zilinganiswe zamiswa mpo maqondana nezikhonkwane. Kumele kuqashelwe futhi kuqinisekisa ukuthi ubuhlonzi obugcwele bophahla lotshani buyagcinwa uma kuloku kuqhutshekwa kwakhiwa kuzungelezwa ijika lenqulu.

Ubukhulu bengqimba yophahla lotshani ezinqulwini luthanda ukuba ngaphansi kunasezigabeni eziyisicaba futhi utshani bophahla obengeziwe bungadingeka. Uphahla lotshani ezinqulwini bungadinga ukunakekelwa kakhulu ngasos osnke isikhathi ngenxa yesimo sezulu esibhebhethlekayo esivame ukuhlotshaniswa nobukhulu obusezingeni eliphansi. Ukusetshenziswa kwezigongolo ezimbili enqulwini, eyodwa ecaleni ngalinye le gumbi, kuzohlinzeka inxazululo enye yezinkinga ezibangelwa yigumbi elingu-90°.

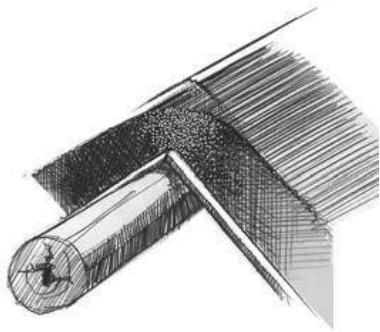

Isigaba esiphuma enqulwini esibonisa ipholi elilodwa kanye nengqimba yophahla lotshani enciphile ngaphezu kwegumbi.

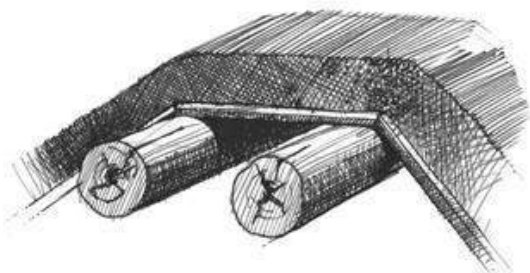

Isigaba esiphuma ngaphakathi kwenqulu esibonisa ukwakhiwa kwamapholi aphindiwe ngengqimba ehlonzi kakhulu nenobukhulu ngaphezu kwegumbi elingama-135 deg.

## IZINQENQEMA

Unqenqema izinyanda ezibekwa kulo, lapho kuhlangukhona undi lophahla kanye nezinqenqema, kumele lugcinwe ejikeni eliphelele ophahleni, kuze kufinyelele ezingeni lokhalo.

# UMHLAHLANDLELA WOKWAKHIWA KOPHAHLA LOTSHANI ENINGIZIMU AFRIKA

---

## OSHMULA

Oshimula bazofanekiswa bese bakhiwa kusetshenziswa okokwakha okungashi okunezimpawu zamandla kagezi cabanga ngokulingana nokodonga lwesakhiwo samatshe abaziwe esakhiwe saqina senziwa saba ngama-200mm ngaphandle uma luxhaswe ngesifanekiso esicatshangiwe, esilungiselelwe ngumuntu onekhono.

Ingaphezulu lenqwaba kumele lengezelwe libe yirediyasi okungenani eyimitha eyodwa (elinganiselwa ukusuka ngaphezu kwenqwaba, eseduzane kakhulu nokwemboze uphahla) ngaphezu kwesimbozo sophahla lotshani. Olwakiwe lwaqiniswa ngaphakathi kwalapho kuphuma khona intuthu (ku-*flue*) ukuzungeleza izingqenqema, noma ukuxhaswa phezu kwezikhonkwane zensimbi ezilula, isibambihlansi esibandakanya imeshi yocingo yensimbi ecwebezelayo (ewubuncane) obungu-10 x 10 x 1 mm, efakwe ukusuka phezulu ku-700 mm, emboza bonke ububanzi obuphelele balapho kuphuma khona intuthu.

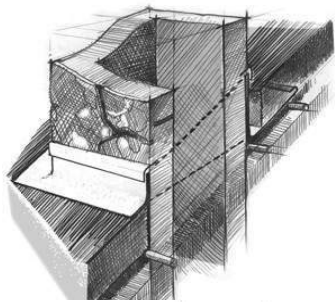

Isigaba esiphambanisayo ukudlula kushimula, esibonisa igatha kanye neminingwane yamafulishi

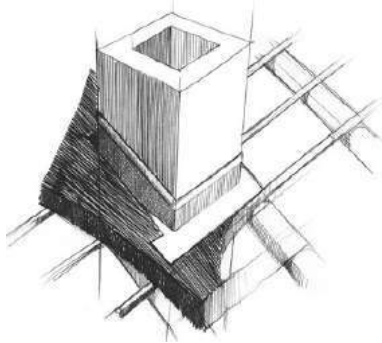

Ukuvimbela uphahla lotshani ukuthi lungasheleli luye phansi

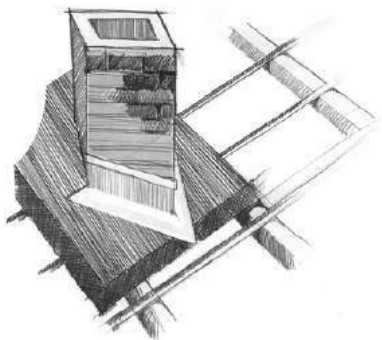

Eminye iminingwane maqondana noshimula ukwehlisa izinga lokuvuza kwamanzi.

# UMHLAHLANDLELA WOKWAKHIWA KOPHAHLA LOTSHANI ENINGIZIMU AFRIKA

## AMAPAYIPI OSHIMULA ENSIMBI

Kusemqoka kakhulu ukuqinisekisa ukuthi isifanekiso sepayipi lokukhipha intuthu kanye nokufakwa kwalo kuyindlela engasoze yabanga ingozi yomlilo eduzane nokokwakha. Ipayipi yokukhipha intuthu akumele ixhunye ngaphakathi kweshafu noma umbhojwana osemzimbeni oyingxenywe yanoma yiluphi uhlelo lokungenisa umoya.

Lapho ushimula uhlinzekwe ngemfoloma yokukhipha intuthu, imfoloma enje kumele yenziwe ngokokwakha okuzokwazi ukumelana nanoma yisiphi isenzo samagesi okuphuma kwentuthu futhi izozabalaza, ngaphandle kokuklewuka noma ukuthambela, amazinga okushisa engabhekana nawo, futhi izakwandiswa ukuya phezulu kubo bonke ubude boshimula.



Insimbi eyisicaba engu-40 x 3 mm  
eshiselwe ecaleni elingaphansi

Ukudepha okungu-200 mm noma  
okungenani ubuhlonzi bophahla lotshani

Ibhokisi elingu-3mm elenziwe igumbi  
ekuphakanyisweni kophahla  
(Ngokuvamile ama-45 deg)

Noma endaweni yebhokisi lensimbi elinesivalo kungabekwa ibhodi enesivalo engu-20 mm.



Ibhokisi lensimbi elinesivalo

Ibhodi Yesimende Nefayibha engu-6 mm

Susa bonke utshani bophahla  
obuthintithekayo ngaphambi kokufaka  
ingubo yokuvimba umlilo

## UMHLAHLANDLELA WOKWAKHIWA KOPHAHLA LOTSHANI ENINGIZIMU AFRIKA

---



Ibhokisi lensimbi elinesivalo elingu-1100 deg elinemfoloma yengubo yokuvimbela umlilo elinokuxhaswa yibhodi yefayibha eyisimende.

Ingubo yokuvimbela umlilo egoqwe cishe ngokulingana nama-20mm ukuya phezulu kokukhipha intuthu



Inethi engucingo ezodonselwa endaweni eqhekekile ngaphambi kokuba isisibekelo sibekwe.

Isisibekelo sikakhonkolo esiqhezulelwe emuva ukuveza ucingo lokunetha esisibekelweni.

Isivalo esingu-50mm sokufaka inhlanganisela yodaka

Uphahla lotshani oluboshelwe kulona, loku kuqinisekisa ukuthi izinyoni zingakwazi ukudonsa uphahla lotshani oluthintithekayo ngaphansi kwesivalo sikakhonkolo.



## UMHLAHLANDLELA WOKWAKHIWA KOPHAHLA LOTSHANI ENINGIZIMU AFRIKA

---



Ibhokisi Lefayibha Eliyisimende elingu-6mm  
Qaphela: Konke okokwakha okushayo  
kusikwa kokukhipha intuthu ngokucishe  
kulingane nama-230mm  
Isivalo sensimbi sebhokisi elifakwe  
kumalathi ngokusebenzisa izikulufu.



Isibonelo sepayipi elikhipha intuthu elifakwe  
ngemfanelo.

# UMHLAHLANDLELA WOKWAKHIWA KOPHAHLA LOTSHANI ENINGIZIMU AFRIKA

---

## IZINQWABA ZOSHIMULA

Ukunakekelwa okukhethekile kuyadingeka lapho izimpawu ezifana nezinqwaba zoshimula kanye namapayipi okungenisa umoya engena ophahleli oluzinzile. Izici ezinje kumele zembathiswe/zifakwe imfoloma ngekhasi lensimbi noma ingilazi eyifayibha enenwe ngaphansi okuyipoliyesta okufleshayo ngaphansi, ngaphakathi naphezu kwendawo engaphezulu yophahla lotshani. Ububanzi bokufleshayo kumele kube okungenani ngama-250 to 300 mm. Ngasesehlakalweni esiphathelene nezinqwaba zamashimula igatha efihlakele iyakhiwa maqondana nobuso obuphezulu boshimula bese ifleshiswa maqondana nayo. Indawo engaphezulu kakhulu yekhasi lensimbi noma igatha eyingilazi eyifayibha iyagqokiswa ngaphansi kophahla lotshani ize ifinyelele cishe kuma-300 mm ngobubanzi.

Amafleshi asemaceleni (kuwo womabili amacala eshimula) azohlenganisa ifleshingi engaphezulu (ngaphansi kwengqimba yophahla lotshani) bese ifleshingi ephansi (ngaphezu kwengqimba yophahla lotshani), ukuvumela amanzi ukuba achitheke ehle phezu kwendawo ewuphahla lotshani. Ukuvimbela uphahla lotshani obungaphezulu nangaphansi kwefleshingi eseceleni ukuba bushelele phansi, uphahla lotshani kumele lubekwe egumbini lokulondoloza uphahla lotshani kumalathi ancikene namafleshingi aphinde futhi amboze amafleshingi aseceleni.

Ingqimba yophahla lotshani akumele ukuba ixhumane nendawo ephezulu kanye namacala amabili eshimula ukuze avumele amanzi avela kumafleshi aphezulu ukuba agelezela ezansi. Uphahla lotshani kumele lulungiswe ukuzungeza ushimula (indawo ephezulu kanye namacala amabili) ukwakha okungenani umsele ocishe ulingane ama-50 mm ngaphakathi kophahla lotshani kanye noshimula.

Ngakwelinye icala, ukuvimbela yinoma ukuvuza okungaba khona ngokuvamile okuhambisana noshimula, amabhilidi kanye/noma uphahla kumele kwenziwe ukuthi izinqwaba zoshimula zikwazi njalo ukungena ophahleli elevelini lonqenqema. Uma loku kungakwazi ukwenzeka, inqwaba ingasontwa ngama-45°, futhi ingakhiwa ngokulinganisene nesakhiwo sophahla, ngakho-ke izosusa inking yokwakha amagatha afihlekile kanye namafleshingi anobunzima, njll, ukuvumela amanzi ukuthi ageleze ngaphandle kokuchithekela phezu kwamafleshingi.

## UTSHANI BOPHAHLA BOKUGCWALISA

Izitepuli eziyizipikili ngaphakathi kogongolo olusandandatho olwenziwe izikhala ezilinganayo ngaphakathi kwemijibe zivumela intambo encane idlule kumastepula

## UMHLAHLANDLELA WOKWAKHIWA KOPHAHLA LOTSHANI ENINGIZIMU AFRIKA

---

bese izungelezela ilathi. Beka utshani bophahla ukuthi benze umbhombodo. Bopha intanjana iqine, sika intanjana elengayo. Donsa intanjana izungelezele ukufihla amafindo ngemuva kwelathi. Sika intambo ibe ubukhulu obulingene bese uyishayela ngesipikili ukuzungeleza umjibe.



Okokugcwalisa uphahla lotshani kungama endaweni yogongolo lokubopha lwezitini noma lodaka.



Isibonelo esingezansi lapho kuqedelwa ukugcwaliselwa kongongolo lokubopha kusetshenziswa utshani bophahla bokugcwalisela.

UMHLAHLANDLELA WOKWAKHIWA KOPHAHLA  
LOTSHANI ENINGIZIMU AFRIKA

---



Isibonelo seziphetho segebhula sophahla lwendlu lotshani bokugcwalisela.

## UKWAKHA UPHAHLA LOTSHANI

### INGQIMBA YOKUNISELA (“SPREILAAG”)

Ngaphambi kokuba ukwakha uphahla lotshani kuqhubeke, ingqimba yentunga ekhethiwe, iziqu zophahla lotshani ezihlanzekile noma intunga yaseKapa yophahla lotshani, eyaziwa njengengqimba yokunisela i-*spray layer* (i-*spreilaag*), iyendlalwa ngokulinganayo phezu kwezikhonkwane zophahla ize yenze ubuhlonzi obucishe bube ngama-5 mm ukuya kuma-8 mm.

Ikamu lotshani lenziwa ngokuhambisana namadayametha amabalwa angu-75 x 3.5 mm- ukuzungeza izipikili zocingo epholini eliqondile elicishe libe ngama-300 mm ubude. Izipikili zihlukaniswe izikhala ezicishe zibe ngama-12 mm, emgqeni oqondile. Izinyanda zotshani zibekwa ziphambane phezu kwekamu bese zicindezelwa phansi ukuze amazele ahlukaniswe yizipikili. Inyanda iyadonswa idluliswe ekamini ukusuka phezulu ukuya endaweni ephansi esiphethweni.

Ingqimba ekhululekile yokunisela, esikelwe ukulingana amalathi okhuni ngaphakathi kophahla ezingeni elisonqememeni, lisetshenziswa ukuqedela unqenqema ukusuka ngaphakathi. Uma ngabe akukho ngqimba yokunisela yentunga ekhethiwe esetshenzisiwe, kuphakanyiswa ukuthi utshani nje obuvamile bophahla lotshani busetshenziswe njengengqimba yangaphansi ukwakha indawo ephansi enobunono ngaphakathi kophahla, (obanele nje ukuvala ingqimba engaphezulu). Lezi zinikeza ukubonakala okunezinzwa ngaphakathi kwaloko kokwembesa uphahla.

Intunga yophahla lotshani noma yokwaxhiwa kophahla lotshani esetshenziswa engqimbeni yokunisela kuzomele ikanywe ngekamu elifanele ukuqinisekisa ukuthi amazele ahlanzekile ngaphambi kokuba afakwe.

**QAPHELA:** Ikamu ingenziwa ngezipikili zensimbi ezingu-75 mm ezifakwa epholini eliqondile. Izinyanda zophahla lwentunga noma ukwaxhiwa kophahla lwentunga kumele zibekwe ngaphezulu kwekamu bese zicindezelwa phansi ukuze amazele ahlukaniswe yizipikili. Inyanda kumele-ke ukuba idonswe idluliswe ekamini ukusuka endaweni ephazulu ukuya kwephansi esiphethweni. Inyanda ngayinye yophahla lotshani noma yokwaxhiwa uphahla lotshani kumele isuswe izidunu ngokusebenzisa ibhodi yokususa izidunu noma indawo ephansi elinganayo ukuqinisekisa ukuthi isidunu esiyisiphetho siyalingana nokuthi zonke izindawo ezicijile zenziwe buthuntu ngaphambi kokufakwa.

## UMHLAHLANDLELA WOKWAKHIWA KOPHAHLA LOTSHANI ENINGIZIMU AFRIKA

---



Ukuqedela okubi esidunwini esiyisiphetho sengqimba yokunisela engafihlwanga yizikhonkwane noma amalathi. Qaphela intanjana yokubopha engaqinisiwe.



Iqedelwe kabi, iziphetho zezinhlamvu ziyabonakala.



Isibonelo esihle izidunu kanye nezinhlamvu eziyisiphetho azibonakali. Izidunu eziyisiphetho zifihlakele. Intanjana iqinisiwe ukuzungelelza ilathi.



Ukuqedwa okuwubunono kwezingqimba zokunisela

# UMHLAHLANDLELA WOKWAKHIWA KOPHAHLA LOTSHANI ENINGIZIMU AFRIKA

---

## OKOKUBOPHA UPHAHLA LOTSHANI

Okokwakha okusetshenziswayo kuele kube intanjana yesisali yotiyela (*i-tar-treated sisal*) noma eyocingo eyinsimbi ecwebezelayo enedayametha engaphakathi kuka-1mm no-1,2mm noma ucingo olwembozwe ngensimbi olunedayametha engu-0.9mm. Ukuthungwa okwenziwe ezikheleni eziwubukhulu obungama-110 mm.

Ukuboshwa kanye nokuqiniswa kophahla lotshani phezu kwezikhonkwane kumele kuhambisane nenhlela yokwakha uphahla lotshani esetshenzisiwe. Futhi akumele kwenziwe izikhala ezihlukene ngokungaphezu kuka-110mm. okokwakha okusetshenziswayo kuzakuba yisisali yotiyela noma insimbi ecwebezelayo noma ucingo olwembozwe ngensimbi olunedayamitha ephakathi kuka-0.9 mm kanye no-1,2 mm.



Intanjana yokubopha yesisali katiyela



Okokubopha kocingo

# UMHLAHLANDLELA WOKWAKHIWA KOPHAHLA LOTSHANI ENINGIZIMU AFRIKA

---

## IZIKHALA ZOKUBOPHA



Isikhala sokubopha esingafanele, esikhulu kunama-110mm. Qaphela ukuthi lezi zintanjana ezithungwe zangaqiniswa.



Isikhala sokubopha esifanele esiku-110mm. Qaphela intanjana iqinisiwe ngokuzungeleza ilathi

## OKOKUBOPHA OKUQINISAYO KOCINGO



Ucingo olungaqinile ukuzungelezela ilathi



## UMHLAHLANDLELA WOKWAKHIWA KOPHAHLA LOTSHANI ENINGIZIMU AFRIKA

---



Ukuboshwa kocingo okuqinisiwe okufanele okuzungeleza ilathi

### OKOKUBOPHA OKUQINISAYO KWENTAMBO



Intanjana engaqinile engaqinisiwe ukuzungeza ilathi okuzovumela ingqimba yophahla lotshani ukuthi ishelele iwele phansi.



Ukuqiniswa kokubopha okufanele.

# UMHLAHLANDLELA WOKWAKHIWA KOPHAHLA LOTSHANI ENINGIZIMU AFRIKA

---

## OKOKUQINISA UTSHANI OBUNTENGENTENGE

Okokuqinisa utshani obuntengentenge kuzakuquketha okuthile kwaloku:

1. Ucingo olwembeswe ngensimbi olunedayametha ewubuncane obungu-3,15 mm
2. Intunga yaseKapa eyizinyanda ezicishe zibe ngama-10 mm.



Okuntengentenge kokubopha okuwucingo olwembeswe ngensimbi ewubuncane obungama-3.15mm

## UKWENZA UPHAHLA LOTSHANI PHEZU KOKUNTENGANTENGAYO

Isisibekelo sophahla lotshani phezu kokuqinisa utshani phezu kokuntengantengayo kweyeme ohlotsheni lokokwakha okusetshenziswayo kanye nobuhlonzi bengqimba, futhi kumele okungenani kube ngama-40 % obuhlonzi bengqimba leyo ecacisiwe. Isisibekelo esiwubuncane, kodwa, akumele sibe ngaphansi kwemininingwane esethebhulini le-2

**UMHLAHLANDLELA WOKWAKHIWA KOPHAHLA  
LOTSHANI ENINGIZIMU AFRIKA**

**UBUHLONZI BEZINGQIMBA ZOKWENZA UPHAHLA  
LOTSHANI**

Ubuhlonzi bengqimba eqediwe ezintweni zokwakha uphahla lotshani ngazinye buzokuba njengokulandelayo:

Izinhlobo	Ubuhlonzi bezingqimba zophahla lotshani ngama-(mm) Loku kubhekwa futhi nobuhtonzi ethebhulini eliboniswe ku- <i>SANS 10400 XA</i>	Isisibekelo phezu kokokuqinisa utshani obuntengentenge noma intanjana ngama-(mm)	Idayametha yesiqu/yesidunu sentunga ngayinye (mm)
Utshani obuvamile noma obucolisekile bokwakha uphahla lotshani	175	70	1,2 to 2,5
Intunga yophahla lotshani	180	80	2,5 to 4

Isisibekelo phezu kokuqinisa utshani obuntengentenge.

Ubuhtonzi jikelele Bophahla lotshani olusha Akumele bube ngaphansi kuka-175mm



Ubuhtonzi obusebenzayo bophahla lotshani lungenhla

lokubopha utshani obuntengentengayo obungekho ngaphansi kuka-70mm. (isisibekelo ngaphezu kokubopha utshani obuntengentenge)

# UMHLAHLANDLELA WOKWAKHIWA KOPHAHLA LOTSHANI ENINGIZIMU AFRIKA

## UKUBEKWA KOPHAHLA LOTSHANI

Ukwakhiwa kophahla lotshani kuzoqalisa onqenqemeni oluphansi lophahla futhi lizobekwa ngokulinganisene nemijibe noma izinkatha.

Izinyanda zokwakha uphahla lotshani esiphethweni sendawo ezinzile sizogijima ngokulinganisene nenqulu yemijibe. Ubuhlonzi obuphelele bophahla lotshani buzogcinwa ukuzungelelza ijika lenqulu. Ngaphandle uma kuye kwacaciswa eminingwaneni yencasiselo, ubuhlonzi kanye nesisindo esiwubuncane kumitha eyenziwe isikwele kabili yengqimba eqediwe ezintweni zokwakha ezibaliwe buzakuba ngokuhambisana nezidingo.



Sibonisa izinyanda zophahla lotshani ngaphezu kwamalathi ngesikhathi inqubo yokwakha uphahla lotshani iqhubeka. Ubude benyanda buhlukaniswa okungenani izikhala ezi-3 okusho ukuthi isihloko kumele sifinyelele okungenani amalathi ama-4.

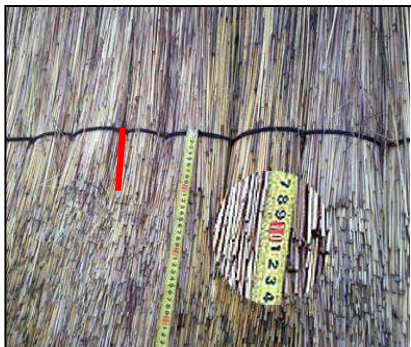

Lesi sithombe sibonisa uphahla lotshani olusanda kwakhiwa, okusukela ekuqaleni lalibekwe ngokungafanele. Qaphela ibanga ukusuka emphethweni ukuya eziphethweni eziyisidunu. (Kucishe kulingane nama-100mm). Lolu phahla lotshani olwenziwe ngokungafanele luzokufinyeza iminyaka yokuphila yophahla.



Ubude obufanele ukuqinisekisa impilo yophahla ehlala isikhathi eside kakhulu ngama-250mm ukuya kuma-300mm. Lo mningwane kumele ubhekisiswe ngokuqaphile ngaso sonke isikhathi ngenkathi uphahla lotshani lwakhiwa. Ukunakekela kumele kwenziwe ukuthi kungeqiwa ama-300mm otshani bokwakha uphahla obuvamile, ngoba kuba sengcupheni yokumoshwa ngumoya.

## IZINKALO

### ULWAZIJIKELELE

Ukwakhiwa kwezinkalo kumele kube njengokucacisiwe ebubanzini bomsebenzi.

1. Ukwakhiwa kwepholi lenkalo kumele kube yinkalo engayodwa noma ezihamba ngazimbili.
2. Kuko kokubili ukwakhiwa kwezinkalo, amalathi okugcina amabili kumele enziwe isikhala esingama-150mm ngaphezu komugqa wakho wokugcina wophahla lotshani. Lo mugqa nawo kumele uthungelwe phansi ukulondoloza uphahla lotshani ezindaweni ezimbili. Kuphinde futhi kuphakanyiswe ukuthi uma ngabe intunga yaseKapa isetshenziswa njengokokuqinisa utshani umugqa wokugcina wophahla lwendlu kumele ulungiswe ngentambo yokuqinisa ewucingo engu-3.15mm. Loku kuzokuqinisekisa ukuthi uphahla lotshani luboshwe ngokufanele ngaphandle kokwenzela phansi okokuqinisa utshani. Lapho ucingo olungama-3.15mm luhlanganisiwe, intunga yaseKapa ingasetshenziswa njengezinto zokuhambisa ugesi.
3. Umugqa wokugcina akumele usikwe. Iziphetho ezingaphezulu zotshani kumele zigoqwe zivale ipholi eliyinkalo bese ziqondaniswa necala ezingabhekene nalo, zemboze uphahla lotshani esiphethweni senqulu sophahla. Ilathi elalifakwe ngaphezu kwama-300mm ngaphezu komugqa wokugcina wophahla lotshani kumele usetshenziswe ukuthungela phansi ingqimba yokugcina yophahla lotshani engaqondene nalutho.
4. Loku kumele kwenziwe kuwo womabili amacala ophahla.
5. Uphahla lotshani enqulwini eyisiphetho yophahla kumele igogelwe ngaphezu kwepholi lenkalo bese iboshelwa epholini lenkalo bese ithungelwa epholini ngokusebenzisa inaliti elihuku.



Qaphela ukuthi uphahla lotshani luye lwasikwa ezinkalweni futhi aluzange lugotshwe njengoba kudingeka.

# UMHLAHLANDLELA WOKWAKHIWA KOPHAHLA LOTSHANI ENINGIZIMU AFRIKA

---



Izinyanda zokwenza izinkalo zotshani kumele zigotshwe ngaphezu kwenkalo bese ziboshelwa ziqine ngokusebenzisa ukuthunga ngaphezu kwezikhonkwane eziphezulu ezimbili ezingaqondene.

6. Emva kokuthi okungenhla sekuqedwe lonke uphahla lotshani kumele luthungelwe epholini lokhalo ngenalti eyihuku noma *i-scomple*.
7. Inqubo engenhla iyadingeka ukuqinisekisa ukuthi umugqa wokugcina wophahla lotshani awusheleli uwe ngaphansi kokwenziwe izinkalo. Le nqubo izophinde futhi ivimbele izinyoni ukuthi zidonse utshani bophahla lotshani.
8. Ngaphambi kokuba inkalo ifakwe uphahla lotshani kanye nokokulungisa okuyizintambo kumele kuphinde kuhloliswe ukuqinisekisa ukuthi kuboshwe kwaqina kanye nokuthi umugqa wokugcina wophahla lotshani uqondile futhi uhleli endaweni efanele.
9. Ezindaweni lapho izinyoni ziyinkinga, kuphakanyiswa ukuthi imeshi yezinyoni enembobo eyidayametha engekho ngaphezu kuka-25mm ibekwe ngaphezu komugqa wokugcina wophahla lotshani futhi yelulelwe kokungenani kuma-900mm ukusuka emnyombweni wokhalo ukuya ezansi kokulenga ngaphezulu. Le meshi yezinyoni nayo kumele ithungelwe epholini lenkalo ukuze liyibambe ingashukumi, ngaphambi kokuba kufanwe inkalo phezu kwayo.
10. Izinhlobo eziwubukhulu obehlukile zophahla zisebenzisa ukwakhiwa kokhalo okwehlukile. Ophahla abafinyelela ebudeni obungama-4m basebenzisa ukwakhiwa kokhalo kwe-lapa okuwububanzi obungama-700mm futhi bungemboza ubukhulu bokhalo obuwubukhulu obunje kalula. Ophahla abawubude obuphakathi kwamamitha a-4 nayi-10 kumele basebenzise inkalo esetshenziswa jikelele ewububanzi obungama-950mm. Ukwakhiwa kokhalo lwezindlu nako kungasetshenziswa lapho ophahla bangebona abegumbi elingu-45 *degrees* noma enobubanzi bobude obuhlukene kakhulu. Izinkatho ezimbili zokugcina ziphathelene nomadaba lwemizwa ngoba zombili izinkalo zingasetshenziswa.
11. Ukwakha ukhalo kumele kusetshenziswe kuzigaba ngobude obuphumeleleyo, ukugwema ukusetshenziswa kwamajoyini.
12. Izinkalo zingakwazi ukufakwa ophahleni lotshani bese okulandelayo kumele kunakekelwe uma ufaka ukhalo. Ukhalo kumele lubekwe lungaqinile esikhundleni salo esifanele futhi kumele sigwaliswe ngokuqinile ngotshani obuyizinyanda obukhululekile, isizathu saloku ukuthi kugwaliswe yinoma yisiphi isikhala esibangekayo ngaphakathi kokhalo kanye nophahla lotshani.

# UMHLAHLANDLELA WOKWAKHIWA KOPHAHLA LOTSHANI ENINGIZIMU AFRIKA

---

13. Emva kokuthi izinkalo sezigcwalisiwe inkalo ingadonselwa phansi phezu kophahla lotshani. Enye nanye intanjana yesithathu kumele idonswe iqiniswe bese iboshwelwa elathini lokugcina, ucingo kumele luthungwe kulo lonke uphahla egumbini ukuze kususwe ukugeleza kwamanzi ukuthi kungalandeli adlule ekuboshelweni kophahla lotshani. Ngokuyibophela kulathi yokugcina, kuyaqinisekiswa ukuthi ukuboshelwa kungaphansi kokwenziwa kokhalo futhi abusoze bathelelwa ngamanzi. Isizathu sokuthi kungani kuwucingo lwesithathu kuphela oluboshiwe, ukwenza umgodi wesikhala sokhalo ngenkathi obonayo osendaweni ephansi elunganisana Nomakho Wophahla Lotshani, ukulinganisa ukhalo egumbini naselevelini efanele. (Kusemqoka ukuthi usebenzise omakhi bophahla botshani ababili, ngoba kunzima kakhulu ukufaka ukhalo ngemfanelo uma ngabe kusetshenziswa Umakhi wophahla lotshani oyedwa.)
14. Ukufakwa kamaqhugwana noma amakhephu ayizikwele kuyafana nokufakwa konqenqema olujwayelekile umehluko wukuthi uphahla lotshani luthungelwa ensikeni evela ngaphezu kobuncane obungama-200mm ngaphezu komugqa wokugcina wophahla lotshani.

## IZINKALO ZOTSHANI

Izinyanda zotshani bokwakha ukhalo kumele bugotshwe ngaphezu kokhalo bese ziboshwa ziqiniswe phezu kwezikhonkwane ezimbili eziphezulu ngokokuqinisa utshani kanye nangendlela efanele yokubopha noma ukuqinisa.

## IZINKALO ZENGILAZI EYIFAYIBHA

1. Izinkalo zengilazi eyifayibha zingenziwa ngobude obungafinyelela ku-9 wamamitha.
2. Imigodi yokubamba engu-2 x 2mm kumele ibhotshozwe noma idrilwe ngaphakathi kwendawo ephansi engu-50mm ilekelele ingxenye yokwenziwa kokhalo lwengilazi eyifayibha.
3. Kuphakanyiswa ukuthi okulandelayo kube yizinga eliwubuncane bezinto zokwakha eziluhlaza ezisetshenziswa ukukhiqiza ukwenziwa kwezinkalo zengilazi yefayibha.
4. Inhloso jikelele yenhlaka noma izinhlaka (*i-resin* noma *ama-resins*) ithathwa njengedingekayo kumuntu onekhono uma kufakwa isicelo esithile.
5. Okuqukethwe yingilazi okuyisibalo esiwubuncane esingama-600 gramu kumitha esiyisikwele ngayinye.
6. Isibalo esiwubuncane sengilazi ukubhekana nereshiyo yenhlaka kumele sibe ngu-2:1.
7. Inani eliphansi kakhulu lokhalo elingama-50mm kumele lelekelelwe ngengqimba eyengeziwe yengilazi engama-600 gramu.
8. Isifanekiso sokhalo kumele kube ngesohlobo, okuzothi uma lufakwa phezulu phezu kokhalo lingene liqine epholini lokhalo.
9. Izinga eliwubuncane benhlaka engu-*FR202* kumele lisetshenziswe uma kukhiqizwa ukhalo lokuvimba umlilo.

# UMHLAHLANDLELA WOKWAKHIWA KOPHAHLA LOTSHANI ENINGIZIMU AFRIKA

## IZINKALO ZESIMENDE NESIHLABATHI

Isisibekelo sokhala sizawuba (ubuncane) obungama-40 mm ubuhlonzi besisibekelo sokhalo lwesimende kanye nesihlabathi (ingxenye eyodwa yosimende ojwayelekile kanye nezingxenye ezine zesihlabathi), ezelulelwa okungenani kuma-750 mm ukusuka okhalweni phansi ecaleni ngalinye lophahla lotshani, olubekwe engqimbeni yolwebu lwe-*polyolefin* eyodwa, lelekelelwa yilathi yensimbi embozwe ngensimbi noma isembozo kulathi noma imeshi ewucingo oluvalwe ngensimbi, olunesembozo kulathi esingekho ngaphansi kwama-20 mm futhi esakhiwe safaneliselwa futhi senziwa saba luhlonzi okhalweni njengoba kuboniswe emdwetshweni wesi-2.

Ukuhlanganiswa kwamajoyini olwebini lwe-*polyolefin* akumele lube ngaphansi kuka-200 mm.

Okokwakha ezinkalweni zesimende nesihlabathi kumele kuqukethe

1. usimende ojwayelekile ohlonipha i-*SANS 50197-1*;
2. isihlabathi esihlonipha izidingo ezifanele ze-*SANS 1083*;
3. imeshi ewucingo eyembozwe ngensimbi ewubuhlonzi obungekho ngaphansi kwama-0,8 mm kanye nembobo engeqi ama-25 mm;
4. izilwebu ze-*polyolefin* ezinobuhlonzi obungekho ngaphansi kuka-250mm.

Sand cement capping 40 mm thick, slightly thickened at the edge -  
isisibekelo sikakhonkolo  
sesihlabathi esiwubuhlonzi obungama-40mm, obenziwe luhlonzi kancane okhalweni.  
100mm overlap with polyolefin membrane - ukukhwelana nolwebu lwe-polyolefin okungama-100mm  
Galvanised metal lath or galvanised wire mesh - Ilathi noma ucingo oluyimeshi- okwembozwe ngensimbi  
Polyolefin membrane - ulwebu lwe-*Polyolefin*  
Bull nose edge - unqenqema olusakhala lenkunzi  
Thatching tied over ridge from both sides - Uphahla lotshani olubushe ngaphezu kokhalo ukusuka emacaleni omabili  
Ridge pole - Ipholi lokhalo  
Rafter - Ingqimba  
King Post - Insika  
Lath - Ilathi

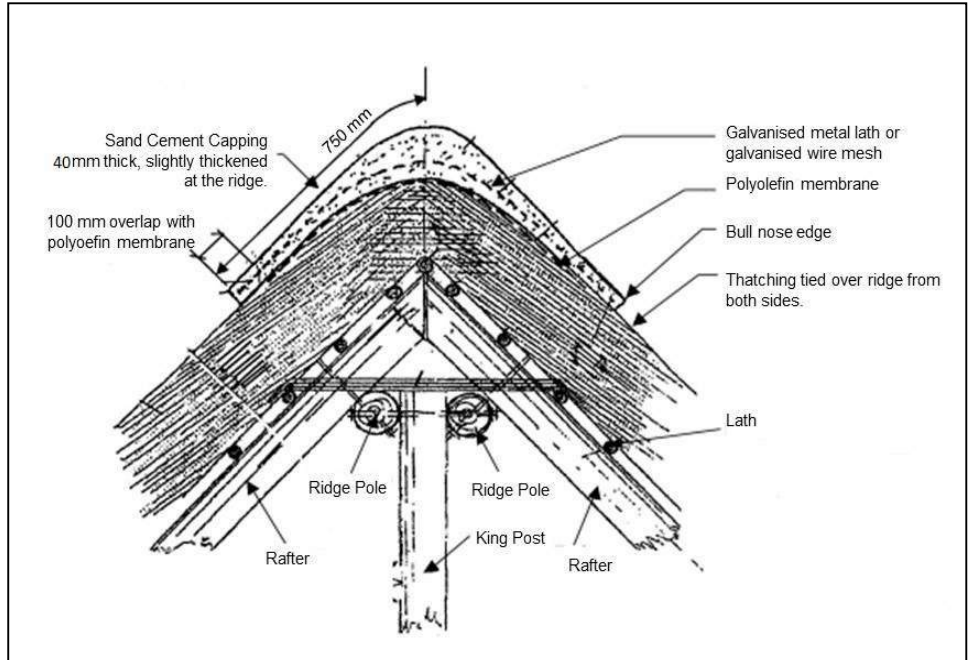



# UMHLAHLANDLELA WOKWAKHIWA KOPHAHLA LOTSHANI ENINGIZIMU AFRIKA

---

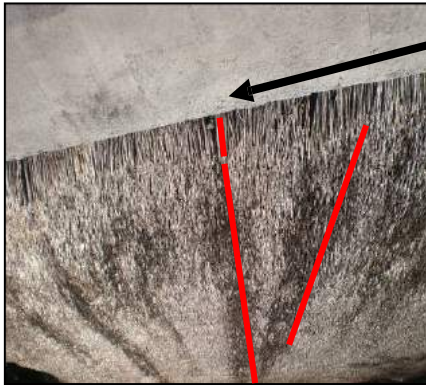

Ukusibekela kumele ukuba kwedluliselwe phansi ukuya eziphethweni eziyisidunu. (Lo mningwane awusebenzi ophahleni olwaxhiwe Ngentunga YaseKapa) Qaphela imisele ebolile iphawulwe ngobubomvu.

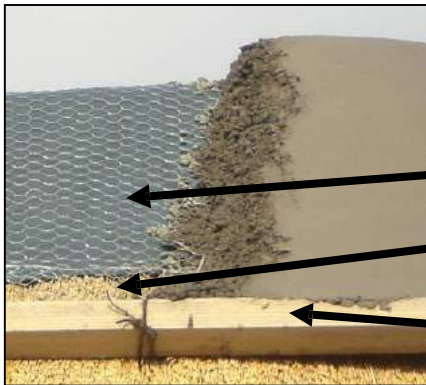

Ukhonkolo kumele ngaso sonke isikhathi umboze iziphetho eziyisidunu. Ugcine ubuhlonzi obungekho ngaphansi kwama-40mm kulo lonke ukhalo.

Ucingo oluyinethi lwepulasitiki engama-micron engu-250.

isikhala esingu-100mm ngaphakathi kwe-*shuttering* kanye nokuqala kwepulasitiki. Ama-*shuttering* angu-150 mm *shuttering*

Udaka Lokwakha: Hlanganisa amabhala ama-2 enhlabathi kakhonkolo nesaka elisodwa likaSimende. Ireshiyo ibe ngu-4:1



Akufanele



Kufanele

## UMHLAHLANDLELA WOKWAKHIWA KOPHAHLA LOTSHANI ENINGIZIMU AFRIKA

---



Ingqimba yokunisela eboshelwe kumalathi ngaphambi kokuba kufakwe isisibekelo sokhalo.

Isisibekelo esifanelo sokhalo oluphansi kakhulu. Qaphela igumbi elibheke phezulu ukukhipha amanzi.



Isisibekelo esingaphezu kokhalo oluphansi kakhulu esingekho ngaphansi kuka-150 mm.

## OKUFAKWAYO JIKELELE

### OKUFAKWAYO OKUNGAMAFLESHINGI

Amafleshingi esikhathini esiningi aba nomphumela ezindaweni ezinezinkinga ezingangeni amanzi. Izici ezixhantela ophahleni oluzinzile kumele zigwenywe ngokusemandleni.



Indlela efanele yokufaka amafleshingi sika izindonga bese usebenzisa isilikhoni ukuvala utshani obungaphansi kwamafleshingi awubuhlonzi obungu $\pm 10$  mm bese alingana ama-200 mm otshani obuphezu kwefleshingi ophahleni lotshani.

### OKUFAKWAYO OKUYITHOLA (ISIKHADLANA EKWELUKWENI/IMESHI YEZINYONI)



Indlela efanele yokufaka imeshi yezinyoni ukuvimbela izimfene (inani eliwubukhulu lobukhulu bezimbobo: 25 mm)  
Imeshi yezinyoni efakwe yazungeleza i-*‘voetlaag’* ethungelwe ukuzungelezela isikhonkwane sokuqala ngocingo olwembozwe ngensimbi.

# UMHLAHLANDLELA WOKWAKHIWA KOPHAHLA LOTSHANI ENINGIZIMU AFRIKA

---

## OKUFAKWAYO OKUYIFASITELA OPHAHLENI LWENDLU

Amafasitela asophahleni lwendlu kumele akhiwe enanini eliwubuncane obungama-30 *degrees*. Amafasitela asophahleni lwendlu, abekwe ngaphakathi kokuzinza kophahla, kanye nakumafasitela “angamashiya” (“*eyebrow*”) elevelini yondi lophahla kumele, ukuze uphahla lotshani luhlale isikhathi esiwubukhulu obude, kumele agwenywe. Ngokwehluka zinokuphakama okungashonile phansi uma kuqhathaniswa nophahla lonke, ngaloko uphahla lotshani olungaphezu kwawo lubola ngesilinganiso esishesha kakhulu.

Yinoma yikuphi ukufakwa kokuthile okungaphansi kwama-45 *degrees* kuzokuba nezinkokhelo zokugcinwa eziphezulu kunophahla lama-45 *degrees* noma ngaphezulu.

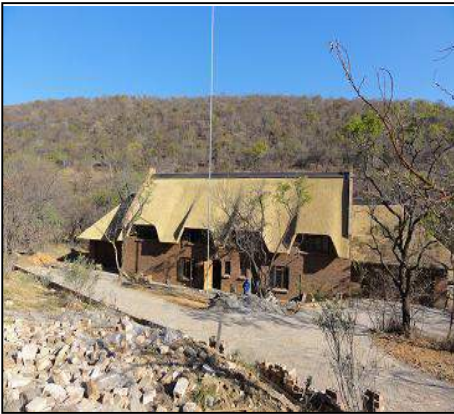

Indlela efanele yokufakwa kwamafasitela asophahleni lwendlu.

## AMAGATHA AYIBHOKISI

Kukhethwa ukuthi kungabi nezigodi ezikhipha amanzi emvula ngomnyango wangaphambili.



Igatha eyibhokisi yensimbi yenziwa ukuthi ifanele lendawo eyinkinga ngaphezu komnyango wangaphambili bese ifihlwa ngokusebenzisa amapholi namalathi.

# UMHLAHLANDLELA WOKWAKHIWA KOPHAHLA LOTSHANI ENINGIZIMU AFRIKA

## INGAPHAMBILI LENDLU NGAPHANDLE ELAKHIWE NGOTSHANI(FACADE)

Amabhilidi akudala angenazindaba angalungiswa kabusha ngokwakha ingaphambili lendlu ngotshani (i-*façade*). Amabhilidi angenazindaba naphuphile angenziwa mahle ngengaphambili lendlu elakhiwe ngophala lotshani.



Lesi sithombe sithathwe lapho kungenwa khona kutholwe izinsizakalo kuleli hhotela, libonisa uphahla lokhethe olukhona. Qaphela ukubukwa okusho okunezinzwa kubhilidi.

## AMASILINGI OPHAHLENI OLWAKHIWE NGOTSHANI

Uma usebenzisa isilingi ophahleni lotshani kumele kugcinwe isikhala esingama-50mm phakathi kwamalathi nesilingi. Loku kuvumela “isikhala sokuphefumula” esanele ukugwema ukujjya.

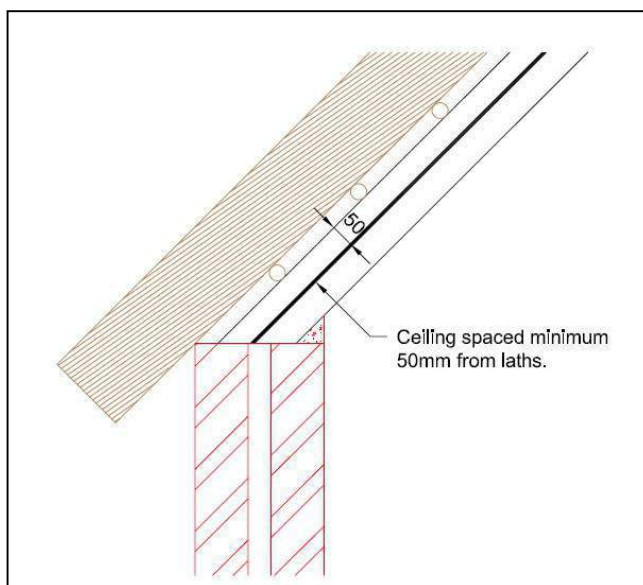

Ceiling space minimum 50mm from laths - Isikhala sesilingi esiwubuncane obungama-50mm ukusuka kumalathi.

# UMHLAHLANDLELA WOKWAKHIWA KOPHAHLA LOTSHANI ENINGIZIMU AFRIKA

## UKUFAKWA KWEGIZA

Umdwebo ongezansi ungumhlahlandlela wokuthi amagiza angamasola kanye namagiza kumele afakwe kanjani ophahleni lotshani

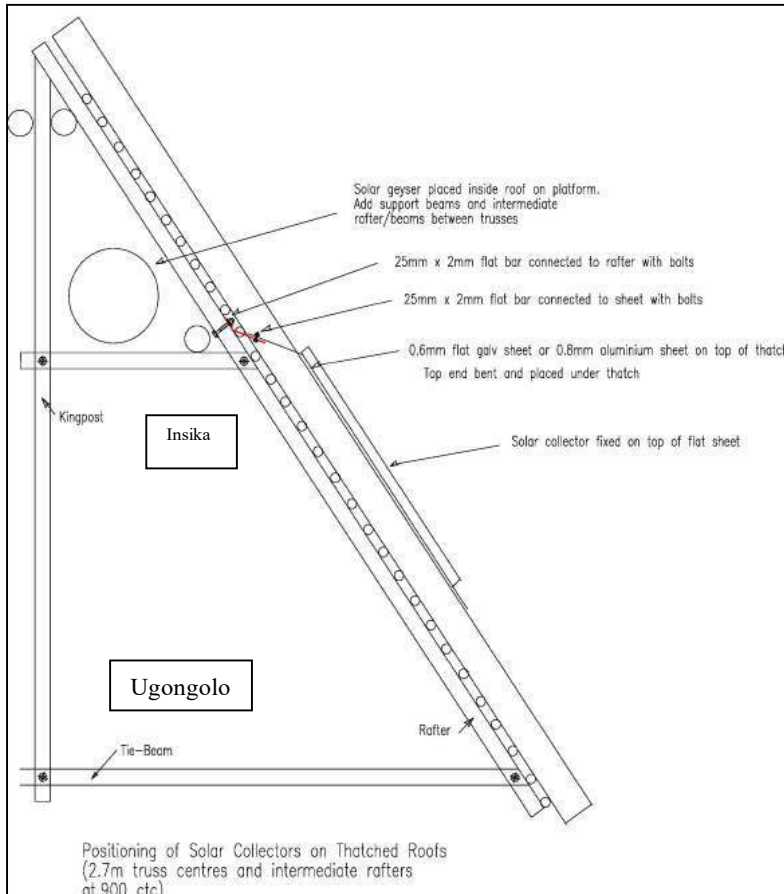

Isikhundla sabantu Abaqoqa ama-Sola

(2.7m truss centres and intermediate rafters at 900 ctc) - Iminyombo yenkatha yotshani obomile engu-2.7m kanye nemijibe yaphakathi naphakathi kuma-900 ctc)

Solar geyser placed inside roof on platform - Igiza yesola ebekwe ngaphakathi kophahla phezu kweplatifomu.

Add support beams and intermediate rafter/beams between trusses -Faka izingogolo zokweseka kanye nomjibe ophakathi nendawo/ izingogolo ngaphakathi kwezintatho zotshani

25mm x 2mm flat bar connected to rafter with bolts - ibha eyisicaba exunye kumjibe ngemishudo engu-25mm x 2mm.

0.6 flat galv sheet or 0.8mm aluminium sheet on top of thatch - ikhasi eliyisicaba elivalwe ngensimbi elingu-0.6. noma ikhasi le-aluminiyam eliphezu kophahla lotshani

Top end bent and placed under thatch -Isiphetho esingaphezulu sigotshiwe sase sibekwa ngaphansi kophahla lotshani

Solar collector fixed on top of flat sheet - Okokuqoqa Isola okugxilise ngaphezu kwekhasi eliyisicaba

Rafter-Umjibe

Tie-Beam-Ugongolo

Positioning of Solar Collectors on Thatched Roofs - Isikhundla sabantu Abaqoqa ama-Sola

(2.7m truss centres and intermediate rafters at 900 ctc) - Iminyombo yenkatha yotshani obomile engu-2.7m kanye nemijibe yaphakathi naphakathi kuma-900 ctc)

# UMHLAHLANDLELA WOKWAKHIWA KOPHAHLA LOTSHANI ENINGIZIMU AFRIKA

---

## UKULONDEKA KWENDAWO YOKUSEBENZELA

Amahhanisi okuphepha kumele agqokwe njalo yinoma ngubani osebenza ophahleni. Ukuphepha endaweni yokusebenzela kumele kuhloniphe ukuphepha kwasendaweni yokusebenzela yezokwakha kanye nemithetho yezokuphepha.



Okufanele, ngamahhanisi okuphepha



Okungafanele, ngaphandle kwamahhanisi okuphepha

## UKULUNGISWA NOKUGCINWA KOPHAHLA LOTSHANI

I-*Thatchers Association of South Africa*, iphakamisa ngokusemandleni ukuthi ngabamakontileka ezokwakha uphahla ngotshani abanesipiliyoni kuphela okumele baqashwe ukufaka nokwenza izinsizakalo zophahla lwezotshani. Inqubo yokuDonsa nokuKama kumele ihlolisiswe kahle kakhulu, ngoba abakho bophahla lotshani abangenasipiliyoni nabangenalo ulwazi bangathatha ukwenza okunqamulelayo okungenza ukuthi ekugcineni uphahla lulimale.

Izinkampani zomshuwalense zicela ukuthi ukugcinwa kumele kwenziwe njalo nje maqondana nophahla lotshani. Umbuzo oqhamukayo ukuthi kulindeleke ukuthi kwenziweni uma kugcinwa uphahla lotshani. Kuhlala njalo kunokuphikisana maqondana nendlela yokubhulasha kanye nokukama. Njengoba kukhona izinhlobo ezimbili zophahla lokwakhiwa ngotshani, okuyintunnga yaseKapa kanye notshani bokwakha uphahla. Kukhona yini umthetho oyigolide okumele usetshenziswe, futhi loku kugcinwa kumele kwenziwe kuzikhathi ezimfushane ezingakanani? Okwamanje eziningi zezindlela ezisetshenziswayo zehlisa ngokwempela isikhathi sokuphila sempilo yophahla.

Ngokugcinwa okufanele ezikhathini ezifushane ezidingekayo, uphahla olwakhiwe ngotshani kumele lube nesikhathi sokuphila esiyiminyaka emide.

Ngaphandle kokugcina indawo ephansi yophahla lotshani isuswe konke okunambuzelayo kanye nezimila, ukugcinwa kumele kwenziwe phezu kophahla lotshani kokwalo. Ukwehla kwezinga kuyabonakala kwesinye isikhathi ukusuka endleleni isisibekelo esibonakala siwubudlabha ngayo.

Ukuhlolwa kophahla, ikakhulukazi ezindaweni ezifana nezigodi, ezindaweni ezingaphansi kwezihlahla, kanye nezindawo ezinemimmango engaphansi kuka-45°, kumele kwenziwe njalo nje ukuthola isimo sengqimba yophahla lotshani. Ngokuvamile, izinga lokulahlekelwa wubuhlonzi kungacatshangelwa ukuthi busesimweni esihle sama-20 mm ukuya ku-25 mm ekwembozeni eminyakeni eyisikhombisa ukuya kweyisishiyagalolunye. Kwingqimba yophahla lotshani ewubuhlonzi obungama-175 mm intanjana yokubopha uphahla lotshani izotholakala ngokuvamile emnyombeni wengqimba (cishe ama-80-100 mm ngaphansi kwendawo ephansi engaphezulu) ngoba intanjana kungenzeka ukuthi ekugcineni igcine ivezwa emva kweminyaka engama-20 noma ngokusondelana nayo.



## UMHLAHLANDLELA WOKWAKHIWA KOPHAHLA LOTSHANI ENINGIZIMU AFRIKA

---

Isikhathi sokuphila sempilo yophahla sizokwengezwa ngokwenziwa kokuhlola okuzobonisa ukuthi ukuDonsa nokuKama kuyadingeka, kusetshenziswa ihalavu lophahla lotshani (*i-leggatt*).

Umuntu udinga ukuqonda umniningwane wobuchwepheshe wophahla lotshani ngaphambi kokuba uvele uvumele nje umakhi wophahla lotshani ongenzamazakho ukuthi akame uphahla. Yinoma yiyiphi inqubo yokukama, ngaphandle uma yenziwe ngemfanelo, yehlisa isisibekelo ngaphezu kokokuqinisa utshani, ngamanye amazwi ubuhlonzi obusebenzayo bophahla kanye futhi nesikhathi sokuphila sempilo yophahla.

Isenzo sokuqala okumele senziwe ukuhlola ubude jikelele bophahla lotshani noma intunga. Uma kutholakala ukuthi zinde ngokwanele, izingqimba zophahla lotshani zingadotshelwa phansi.

Le ngxenye yophahla lotshani isemqoka kakhulu, ngoba ubude besiqu ngezansi kwentanjana ngokwempela inomthelela oqondile eminyaneni yempilo yokuphila kophahla lotshani. Okulandelayo, intanjana yokubopha kumele iqiniswe ngaphansi kwendawo engaphansi yophahla, futhi yilapho kuphela inqubo yokukama izoqalisa. Bheka izithombe ezingezansi.

Uma ubheka isithombe esingakwesokudla umuntu angakwazi ukubona ingxenye engaphezulu esandleni sesinxele sophahla eselenziwe izinsizakalo, ingxenye ephakathi nendawo isadinga ukuba yenziwe izinsizakalo bese indawo ephansi enezingqimba ezidonselwe emuva.



Ukuqiniswa kwentanjana emva kokwehlisela phansi ingqimba yangaphandle yezinyanda

# UMHLAHLANDLELA WOKWAKHIWA KOPHAHLA LOTSHANI ENINGIZIMU AFRIKA

---



Isithombe esisezansi sibonisa ngokucacile ukuthi uphahla lotshani luphakanyiswa kanjani emva kokwenziwa izinsizakalo.



**UKULUNGISWA KOPHAHLA**  
**LOTSHANI – UKULWENZA**  
**FUTHI/UKULWENZA**  
**KABUSHA**

**(Okulandelayo akusebenzi ophahleni lweNtunga yaseKapa, akufanele neze kube nengqimba yesibili eyengezwayo kumabhilidi akhiwe ngeNtunga yaseKapa)**

Konke okokwakha kophahla lotshani okubolile kumele kukhishwe ngokuphelele ngenkathi kugcinwa futhi kufakwe obusha, obupakishwe ngokuqinisiwe, okungokokwakha okukhulile. Uphahla lonke kufanele luphinde luhlanzwe kususwe okokwakha okukhumukile, ngokubhrasha ngaphambi kokufaka ingqimba entsha yophahla lotshani.

**Isifanekiso sokuqala sesakhiwo sophahla sidinga ukuba sibe ngesanele ukuthi sithwale isisindo esengeziwe sengqimba yesibili yophahla lotshani. KUSEMQOKA UKUHLOLA UBUQOTHO BESAKHIWO SOKHUNI EKUKWAZINI KWASO UKUTHWALA ISISINDO ESENGEZIWE SENGQIMBA YESIBILINGAPHAMBI KOKUBA IFAKWE.**

Ukuphinde ugqokise isisibekelo sophahla lotshani (ukufakela ingqimba entsha yophahla lotshani phezu kwengqimba yokuqala) kuba yisidingo uma ukubola sekufinyelele esigabeni lapho ukulungiswa kuvezeka endaweni ephansi.

Uma nje kokulungiswa kuveziwe, amanzi emvula angahanjiswa aqonde phansi ngokudluliswa ophahleni lotshani ngokuhambisa imithungo yentanjana ngaphakathi kwengqimba yophahla lotshani kanye nangaphakathi kwebhilidi. Ukuvezwa kokulungiswa kuzakuba nomphumela ongekho maqondana nokuphela komthungo wentanjana kuphela, kodwa nokwehla kwesisibekelo sophahla sonke uma uphahla lotshani lulahlekelwa wukuminyana. Ngenxa yokuthi uphahla lotshani ngokokwakha kwemvelo, kuzokwehla esikhathini esithile esinikeziwe, kuye ngezimo zezwe zaleyo ndawo.

Ubuhlonzi bengqimba yesibili, ebizwa ngokuthi okokwembesa noma okwaphezu kophahla lotshani, kuzokuba ngokuhambisana nethebhuli le-2 (bheka amakholomu-2, 3 kanye no-5 ethebhuli lesi-2 ku-SANS 10407:2015 Isihumusho sesi-2) Iphuzu

## UMHLAHLANDLELA WOKWAKHIWA KOPHAHLA LOTSHANI ENINGIZIMU AFRIKA

---

elisemqoka kakhulu okungukuthi, isisibekelo phezu kotshani bokubopha akumele sibe ngaphansi kwama-70 mm.

Uma ngabe ingqimba yesibili iyatholakala kuzomele isuswe kuqala ngaphambi kokuba okokubeka phezulu noma ngaphezu kophahla lotshani kusetshenziswa (okusho ukuthi akusoze kwaba nezingqimba zophahla lotshani ezingaphezu kwe-2 phezu kwesakhiwo sophahla).

---

## UMHLAHLANDLELA WOKWAKHIWA KOPHAHLA LOTSHANI ENINGIZIMU AFRIKA

---



Kusemqoka ukusika yinoma yiziphi izihlahla noma amahlathi kuye emuva okulengela phezu kophahla olwakhiwe ngotshani, ukuqinisekisa ukuthi okwenza izithunzi akuweli ngaphezu kophahla futhi akubangeli ukubola. Amagatsha asondele kakhulu noma athinta uphahla nawo azolimaza futhi uphahla lotshani uma umoya uvunguza. Ukugcina uphahla lungasondelene namagatsha, kuzokhuphula isikhathi sokuphila sophahla.



## UKUPHEPHA EMLILWENI

### AMABANGA OKUPHEPHA

Amabanga okuphepha ukuvela kwezinye izakhiwo kanye nemingcele njengokwe-SANS 10400-T

#### 4.12.2 Ophahla abakhiwe ngotshani

4.12.2.1 Amabanga okuphepha atholakale ku-4.2 kumele, ngaphandle kokubheka amakilasi okuhlalisa anikezwe ethebhulini le-2, esekwe ngesisindo somlilo esiphezulu kakhulu lapho uphahla lotshani lungavikelekile bese Inani-A kufomula lizakwesekwa maqondana nayo yonke indawo engaphambili yobuso bendlu (*i-façade area*) yebhilidi elibhekene nenqenqema, kunganakwa uhlobo lodonga noma okuvulekile kanye nokubandakanya uphahla. Lapho uphahla lwendlu luhlinzekwa uhlelo lokuvimbela umlilo, evivinye ngokuhambisana ne-ASTM E108 amabanga okuphepha azokwesekwa ezisindweni zomlilo ezilandelayo,

- a) Umphumela wesivivinyo-A – isisindo somlilo esiphansi
- b) Umphumela wesivivinyo-B – isisindo somlilo esiphakathi nendawo
- c) Umphumela wesivivinyo-C – isisindo somlilo esiphezulu kakhulu

QAPHELA Umphumela wesivivinyo-C ulingana nophahla olungavikelekile.

4.12.2.2 Ngokungabhekeli izidingo zika-4.12.1, *i-lapa* elakhelwe uphahla lotshani linendawo yohlelo lophahla engaphansi kuka-20 m<sup>2</sup>, ezimele yodwa futhi engaxhumananga nanoma yiliphi ibhilidi akumele lakhiwe lisondelane

- a) ngama-1,0 m kunoma yiluphi unqenqema, futhi
- b) Ibanga lokuphepha kunoma yiyiphi ibhilidi lutholwe ku-4.2, ngaphandle uma kuwudonga lukakhonkolo noma isakhiwo samatshe abaziwe (*i-masonry*) enobude obungaphezu kuka-0,3 m ngaphezu komugqa ophansi wophahla futhi elidluliselwa ecaleni ngalinye lelapa ngama-1,0 m ngenkathi lakhiwa.

4.12.2.3 Umuntu onekhono (unjiniyela wezemililo) uzokwenza ukuhlolwa okunengqondo ukuthola ukuvumeleka bokwakha ibhilidi elifulelwe ngotshani ngokusondelene nebhilidi eselikhona.

4.12.2.4 Amabhilidi nama-lapa anendawo yohlelo lophahla olwakhiwe ngotshani engaphezu kuka-300 m<sup>2</sup> noma esondelene nobukhulu obungama-4,5 m kunoma yiyiphi inqenqema kanye nokuthi amabanga okuphepha ukusuka ebhilidini elikhona elitholakala ku-4.2, lizohlinzekwa ngezinye izinhlelo zokuvimbela umlilo ezivunyelwe ngokuhambisana nohlelo

# UMHLAHLANDLELA WOKWAKHIWA KOPHAHLA LOTSHANI ENINGIZIMU AFRIKA

---

lophahla langempela okumele lusetshenziswe, futhi lugcinwe njengoba kucaciswe ngumkhiqizi wezihlelo ezinje.

4.12.2.5 Amabhilidi nama-lapa anophahla olwaxhiwe ngotshani ezindaweni ezinobukhulu befleshi yombani engaphezu kuka-7 (bona i-SANS 10313) kumele zihlinzekwe ngohlelo lokuvimbela umbani, olufanekiswe lwaphinde lwafakwa ngabantu abanamakhono ngokuhambisana nezidingo ezifanele ze-SANS 10313 ne-SANS 62305-3.

4.12.2.6 Amabhilidi nama-lapa lapho kusetshenziswa amakhondaktha (izibopho zocingo) engqimbeni yophahla lotshani, ezindaweni ezinobukhulu befleshi yombani obungaphezu kuka-3 (bheka i-SANS 10313), kumele zihlinzekwe ngohlelo lokuvimbela umbani, olufanekiswe lwaphinde lwafakwa ngabantu abanamakhono ngokuhambisana nezidingo ezifanele ze-SANS 10313 ne-SANS 62305-3.

## IZINSIZAKALO

Ukunikezwa kwamandla kagesi kanye nezintambo zocingo kumele kungene ebholidini nokuhambisayo (amadakthi/ama-*conduit*), futhi zonke izintambo ezifakiwe zikagesi esikhaleni esisophahleni kumele szifakwe kokuhambisa kwepulasitiki, bese wonke amabhokisi ezinhlanganiso ayavalwa.

## UKUSETSHENZISWA KWAMAKHONDAKTHA

Ukuba khona kwekhondaktha yensimbi noma yanoma yiluphi olunye uhlobo esakhiweni sophahla kusethulela ingozi yokuhanjiswa kombani uma ngabe uphahla lungavikelekile. Ngakho-ke kusemqoka ukuthi imithetho ye-SANS kumele ilandelwe ngamandla ukuvimbela yinoma yikuphi ukumosheka okungabangwa ngumbani.

Akumele nangaphansi kwanoma yisiphi isimo ukuthi amapayipi ensimbi, izintambo noma izingcingo zikagesi zixhumane ngokuqondile nophahla lotshani. Izinsizakalo zikagesi kanye nezinye (ezocingo kanye ne-TV) kumele njalo zingene ebholidini elevelini esendaweni ephansi. Akukho zintambo noma zingcingo okumele zidluliswe ngaphakathi nophahla lotshani.



Okokudlulisa umbani okuphindaphindiwe.

# UMHLAHLANDLELA WOKWAKHIWA KOPHAHLA LOTSHANI ENINGIZIMU AFRIKA

## UHLELO LOKUVIMBELA UMBANI (I-LIGHTNING PROTECTION SYSTEM (LPS))

Ukuze kutholakale ukuphepha Kwezomlilo ireferensi kumele ibhekiswe ku-SANS 10400-T. Kusemqoka ukuqinisekisa ukuthi isifanekiso sakho kanye nokufakwa kuhlonipha i-LPS.

Okungenani okokuvikela umbani kweleveli ye-III (bheka i-SANS 62305-3) kuzosetshenziswa ecaleni lwezakhiwo ezifulelwe ngotshani. Uma ngabe insika yensimbi isetshenziswe njenge-LPS, izokufanekiswa ngokuhambisana ne-SANS 10225. Ukuvikelwa kuzohlelwa yinsika eyodwa noma eziningi ezizimele ngokwazo. Indawo yokuvikela kwensika/kwezinsika izokubandakanya iziphetho zamagebhuli, amashimula, ama-*antenna*, amapayipi omoya kanye nanoma yiyiphi into yensimbi. Izingcingo zocingo, ukuxhumana kwezinsizakalo okuhamba phezu kwamakhanda ezingena ekunikezelweni kukagesi noma ezinye izingcingo zensimbi noma amapayipi akumele angene esakhiweni ngokudlula ophahleni lotshani noma eduzane nalo. Ibanda ukusuka ku ukuya ophahleni lotshani akumele ibe ngaphansi kuka-1 000 mm.

Izinsimbi ezisetshenziswa ekwakhiweni kophahla lotshani kumele zibhondwe bese ziqondiswe phansi (zenziwa ukuthi zivimbele ukushaywa ngumbani). Amapayipi amanzi, amapayipi omoya, amathangi, amapayipi egesi, ama-*antenna*, izingcingo zocingo noma zezinsimbi, ama-alamu azisa ngabantshontshayo kanye nezintambo zikagesi kanye nokokuvikela ucingo okuvela endaweni ephansi (i-*conduit*) ngaphakathi kwama-1 000 mm ophahla lotshani azovikelwa, abhondwe bese egxiliswa phansi ngokuhambisana ne-SANS 10142-1.

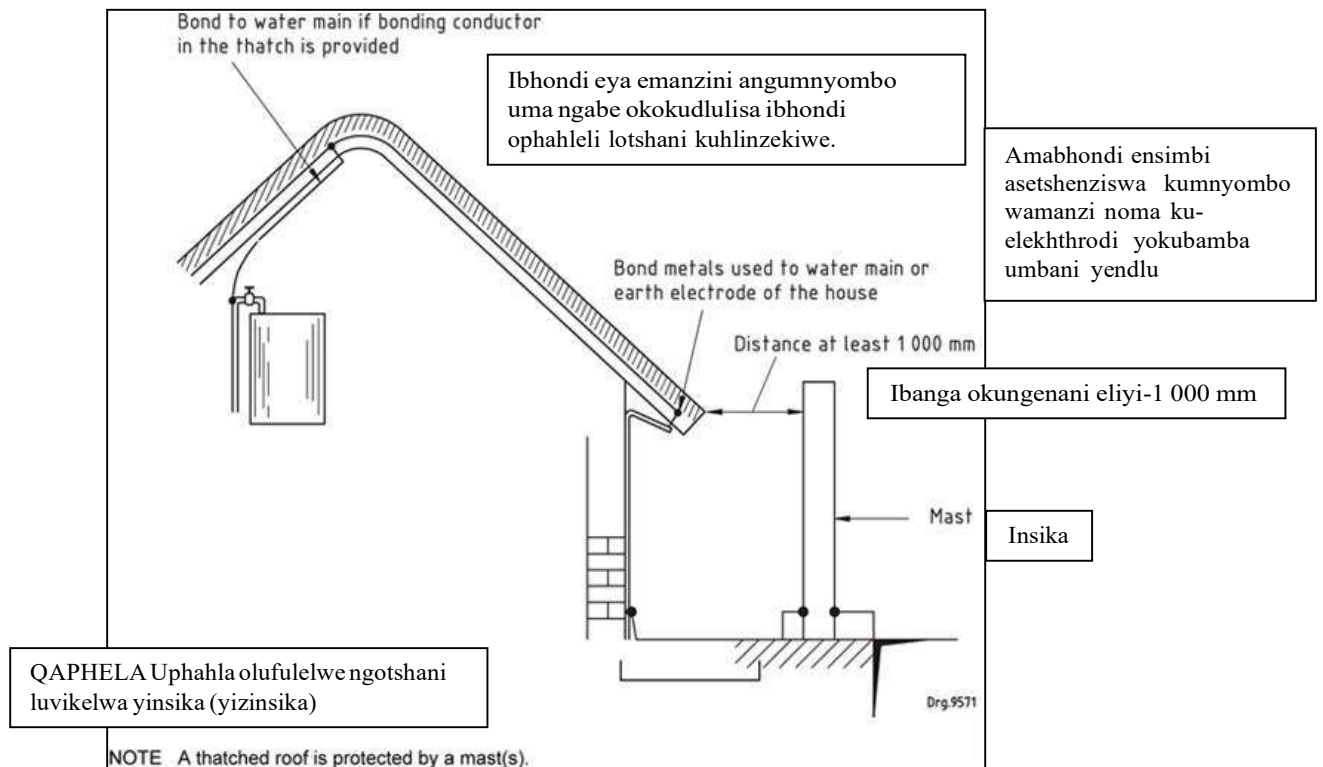



UMHLAHLANDLELA WOKWAKHIWA KOPHAHLA  
LOTSHANI ENINGIZIMU AFRIKA

UKUMINYANA KOMBANI OBENYEZA PHANSI (N<sub>G</sub>)

Ithebhuli-C.1 — Ukuminyana kombani obenyeza phansi					
1	2	3	4	5	6
Idolobha	N <sub>g</sub>	Idolobha	N <sub>g</sub>	Idolobha	N <sub>g</sub>
Aberdeen	1,8	Gobabis	2,6	Paarl	0,2
Albertinia	0,5	Golden Gate	6,4	Petrus Steyn	4,4
Alexandria	0,8	Grabouw	0,2	Pietermaritzburg	7,0
Aliwal North	5,3	Graaff-Reinet	2,5	Piet Retief	11,7
Aranos	1,6	Grahamstown	1,4	Piketberg	0,2
Aroab	1,7	Greytown	5,5	Polokwane (Pietersburg)	3,6
Barberton	7,5	Groblersdal	5,1	Pongola	6,3
Beaufort West	1,7	Harding	5,5	Port Alfred	1,4
Belfast	7,3	Harrismith	9,4	Port Elizabeth	0,9
Bela Bela	7,5	Heidelberg (WC)	8,0	Potchefstroom	7,0
Benoni	7,5	Heilbron	5,8	Pretoria	7,5
Bergville	6,3	Hermanus	0,1	Prieska	3,0
Bethal	8,6	Hluhluwe	6,0	Prince Albert	0,6
Bethlehem	6,4	Hoedspruit	2,8	Queenstown	5,2

**UMHLAHLANDLELA WOKWAKHIWA KOPHAHLA  
LOTSHANI ENINGIZIMU AFRIKA**

Bethulie	3,3	Humansdorp	1,1	Reddersburg	6,4
Bloemfontein	5,2	Irene	7,2	Richards Bay	5,2
Bloemhof	4,8	Jagersfontein	2,2	Richmond (KZN)	8,0
Blyderivierspoort	4,5	Johannesburg	7,5	Riversdale	0,2
Boksburg	7,5	Jozini	5,6	Roedtan	4,9
Brakpan	7,5	Keetmanshoop	1,2	Rustenburg	8,1
Brandvlei	0,9	Kempton Park	7,5	Sabie	3,2
Brits	8,0	Keiskammahoek	2,0	Satara	1,5
Bultfontein	3,6	Kimberley	4,8	Schweizer-Reneke	5,6
Burgersdorp	3,3	King William's Town	1,1	Scottburgh	3,0
Butterworth	0,9	Klerksdorp	7,0	Senekal	4,7
Cala	5,2	Knysna	0,4	Sishen	3,4
Caledon	0,2	Komatipoort	2,6	Skukuza	2,3
Calvinia	0,7	Kroonstad	5,8	Somerset East	0,8
Cape Town	0,3	Krugersdorp	7,0	Springbok	0,6
Carletonville	7,5	Kuruman	3,0	Springs	7,5
Carnarvon	1,1	Ladybrand	5,4	Standerton	7,6
Carolina	9,0	Ladismith (WC)	0,7	Stanger	3,5

**UMHLAHLANDLELA WOKWAKHIWA KOPHAHLA  
LOTSHANI ENINGIZIMU AFRIKA**

Cathcart	1,6	Ladysmith (KZN)	9,0	Stellenbosch	0,3
Cedara	8,0	Laingsburg	0,6	Steytlerville	1,7
Ceres	0,2	Lichtenburg	5,5	Sutherland	0,9
Christiana	6,4	Loskop	4,3	Swakopmund	0,5
Colenso	7,8	Lüderitz	0,4	Tarkastad	3,4
Colesberg	3,0	Lydenburg	5,0	Thabazimbi	2,1
Cradock	5,8	Machadodorp	8,7	Theunissen	5,2
De Aar	2,5	Mafikeng	5,6	Touws River	0,3
Delareyville	5,4	Makhado	1,5	Tsumeb	4,0
Donnybrook	8,5	Malmesbury	0,1	Tzaneen	4,1
Doornfontein	7,3	Mandini	3,4	Umtata	3,0
Dordrecht	2,6	Margate	1,8	Uniondale	0,6
Douglas	4,0	Marikana	6,9	Uppington	2,2
Dundee	9,2	Matatiele	6,6	Utrecht	9,0
Durban	4,4	Middelburg (EC)	3,3	Ventersdorp	5,6
East London	1,6	Middelburg (Mpumalanga)	4,6	Vereeniging	7,5
Edenvale	5,6	Modimolle	7,0	Victoria West	1,4
Elliott	4,2	Mokopane	3,4	Villiersdorp	0,4

UMHLAHLANDLELA WOKWAKHIWA KOPHAHLA  
LOTSHANI ENINGIZIMU AFRIKA

---

Empangeni	4,1	Molteno	1,6	Vredendal	0,2
Ermelo	9,0	Montagu	0,2	Vryburg	3,0
Eshowe	5,3	Mooi River	6,9	Vryheid	8,9
Evander	8,5	Mookgopong	6,0	Walvis Bay	0,2
Flagstaff	4,9	Mossel Bay	0,5	Welkom	5,0
Fort Beaufort	1,4	Murraysburg	1,9	Willowmore	1,5
Fraserburg	1,3	Nelspruit	2,7	Windhoek	2,3
George	1,5	Nossop	2,2	Witbank	7,5
Georgedale	5,6	Noupoort	7,4	Zeerust	4,2
Germiston	7,5	Ohrigstad	4,2		
Giant's Castle	13,0	Oshakati	2,3		
Gobabes	0,2	Oudtshoorn	0,5		

# UMHLAHLANDLELA WOKWAKHIWA KOPHAHLA LOTSHANI ENINGIZIMU AFRIKA

Umbiko wokufaka we-LPS uzonikezwa ngumuntu oneziqu/ofanelekile.

Amdt 1

<b>1. Location</b>												
Physical address:												
Name of building:												
Erf/Lot No.:					Suburb/Township:							
District/Town/City					Province:							
Type of inspection:		Repeat <input type="checkbox"/>			Additional <input type="checkbox"/>			Visual <input type="checkbox"/>				
Acceptance <input type="checkbox"/>		Design <input type="checkbox"/>			During construction <input type="checkbox"/>							
Lightning ground flash density ( $N_g$ ): (Flashes/km <sup>2</sup> /year)				Accepted annual frequency of lightning flashes to structure ( $N_c$ ):								
Protected space (description):												
Risk assessment done for system?		Yes <input type="checkbox"/>		No <input type="checkbox"/>		Risk assessment report attached?		Yes <input type="checkbox"/>		No <input type="checkbox"/>		
<b>2. Risk assessment</b>												
User-specified acceptable risk				User-calculated risks:			Risk of direct strike $R_D$	Risk of indirect strike $R_I$	Calculated risk $R$			
Tolerance on risk: $R_T$	1	Loss of human life					10 <sup>-3</sup>	1				
	2	Loss of services					10 <sup>-3</sup>	2				
	3	Loss of cultural heritage					10 <sup>-3</sup>	3				
<b>3. Air-termination system</b>												
Thatched roof:		Yes <input type="checkbox"/>		No <input type="checkbox"/>		Metal roof: Yes <input type="checkbox"/>		No <input type="checkbox"/>		Hazardous location: Yes <input type="checkbox"/>		No <input type="checkbox"/>
Flat roof:		Yes <input type="checkbox"/>		No <input type="checkbox"/>								
LPS level:		I <input type="checkbox"/>		II <input type="checkbox"/>		III <input type="checkbox"/>		IV <input type="checkbox"/>				
Height of structure:			Height of mast/catenary:			Number of mast(s):						
Mast design in compliance with SANS 10225:				Supplier of mast:			Tel. No.:					
Air-termination system:			Protective angle $\alpha$ :			Rolling sphere radius, m:						
Material used:		Lead <input type="checkbox"/>	Steel (stainless or galvanized) <input type="checkbox"/>		Titanium <input type="checkbox"/>	Copper <input type="checkbox"/>	Aluminium <input type="checkbox"/>	Zinc <input type="checkbox"/>				
<b>4. Down conductor system</b>												
Material used:		Steel (stainless or galvanized) <input type="checkbox"/>		Copper <input type="checkbox"/>		Aluminium <input type="checkbox"/>		Spacing between conductors m				
Size of DTS conductor used, mm <sup>2</sup>				Is existing structure used as down conductor?		Yes <input type="checkbox"/>	No <input type="checkbox"/>	Description:				
Reinforced concrete/metal used?		Yes <input type="checkbox"/>		No <input type="checkbox"/>								
Mesh design:		Number of down conductors:		Spacing between ring conductors:		Accessible joints/terminations:		Yes <input type="checkbox"/>	No <input type="checkbox"/>			
Accessible joints/terminations:				Pop-riveted <input type="checkbox"/>		Soldered <input type="checkbox"/>						
NOTE The following abbreviation has been used:												
DTS down conductor termination system												

Amdt 1

# UMHLAHLANDLELA WOKWAKHIWA KOPHAHLA LOTSHANI ENINGIZIMU AFRIKA

Isitifiketi sokugcina okufakiwe se-LPS sizonikezwa ngumuntu oneziqu/ofanelekile.

Amdt 1

5. Earth-termination system			
Earthing arrangement	Type A	Type B	Particular conditions: Reason for earthing arrangement:
Final equivalent earth resistance obtained:		$\Omega$	Soil resistivity: <span style="float: right;"><math>\Omega\text{m}</math></span>
6. Lightning equipotential bonding			
Equipotential bonding bar installed:		Yes <input type="checkbox"/>	No <input type="checkbox"/>
System connected to bonding bar installed:		Telecommunication <input type="checkbox"/>	Pipes <input type="checkbox"/> Electrical <input type="checkbox"/> Equipment <input type="checkbox"/>
Material used:		Steel (stainless or galvanized) <input type="checkbox"/>	Copper <input type="checkbox"/>
Conductor size used to connect bonding bar to ETS, mm <sup>2</sup> :		Conductor size used to connect metal installation to ETS, mm <sup>2</sup> :	
7. Surge protective devices (SPDs)			
Design drawing No.:		Main incomer distribution board: Load current A	Prospective short-circuit current rating kA
SPD, class I: nominal a.c. voltage $U_N$ V		Impulse current $I_{imp}$ : kA (10/350 $\mu\text{s}$ )	Max. back-up fuse current $I_k$ kA
		Voltage protection level at $I_{imp}$ : kV	Follow current extinguishing capability: kA <sub>rms</sub>
SPD, class II: nominal a.c. voltage $U_N$ V		Nominal discharge current $I_n$ kA (8/20 $\mu\text{s}$ )	Max. mains overcurrent protection A
		Voltage protection level at $I_n$ : V	Temporary overvoltage (TOV) $U_T$ V/5 s
8. Certification			
I/We, being the person(s) responsible for the design <sup>a</sup> , installation <sup>a</sup> , inspection <sup>a</sup> , testing <sup>a</sup> , of the lightning protection system (LPS), am/are competent to certify that the LPS complies with the requirements of SANS 10313.			
<sup>a</sup> Delete where not applicable.			
9. Details of LPS designer			
Name:		ID No.:	Company:
Tel No.:		Signature:	Date:
10. Details of LPS installation installer			
Name:		ID No.:	Company:
Tel No.:		Signature:	Date:
11. Details of fixed electrical installation			
Any work performed on the fixed electrical installation with regard to the LPS shall be witnessed by an accredited person.			
Installation safety report No.:		Date of installation safety report:	
12. Approval signature			
Name of lightning protection inspector:		Company:	
Tel No.:		Date:	
ID No.:		Signature:	
NOTE The following abbreviations have been used:			
DTS down conductor termination system			
ETS earth-termination system			

Amdt 1

**UMHLAHLANDLELA WOKWAKHIWA KOPHAHLA  
LOTSHANI ENINGIZIMU AFRIKA**

Amdt 1

<b>1. Location</b>					
Physical address:					
Name of building:					
Erf/Lot No.:			Suburb/Township:		
District/Town/City:			Province:		
LPS level:	I <input type="checkbox"/>	II <input type="checkbox"/>	III <input type="checkbox"/>	IV <input type="checkbox"/>	Date of last inspection:
Type of inspection:	Repeat <input type="checkbox"/>	Additional <input type="checkbox"/>	Visual <input type="checkbox"/>	Acceptance <input type="checkbox"/>	
<b>2. Details of LPS installation installer</b>					
Name:		ID No.:		Company:	
Tel No.:		Signature:		Date of installation:	
<b>3. Details of fixed electrical installation</b>					
Any work performed on the fixed electrical installation with regard to the LPS shall be accompanied by an Installation safety report issued by an accredited person.					
Original Installation safety report No.:			Date of Installation safety report:		
<b>4. Maintenance of LPS structure</b>					
<b>4.1 Air-termination system (ATS)</b>					
Connection between ATS and down conductor:		Acceptable <input type="checkbox"/>	Replaced <input type="checkbox"/>	Refastened <input type="checkbox"/>	
Material used:	Lead <input type="checkbox"/>	Steel (stainless or galvanized) <input type="checkbox"/>	Titanium <input type="checkbox"/>	Copper <input type="checkbox"/>	Aluminium <input type="checkbox"/> Zinc <input type="checkbox"/>
Straightness of mast used:		Acceptable: <input type="checkbox"/>	Replaced <input type="checkbox"/>	Continuity of ATS:	
<b>4.2 Down conductor system (DTS)</b>					
Material used:		Steel (stainless or galvanized) <input type="checkbox"/>	Copper <input type="checkbox"/>	Aluminium <input type="checkbox"/>	Electrical conductivity of conductors: $\Omega$
Size of DTS conductors used, mm <sup>2</sup> :			Accessible joints/terminations:		
Electrical conductivity of shielding measures: $\Omega$			Electrical conductivity of equipotential bonding lines: $\Omega$		
If reinforced concrete/metal parts are used as down conductors, is conductivity still present?					Yes <input type="checkbox"/> No <input type="checkbox"/>
<b>4.3 Earth-termination system</b>					
Earthing arrangement:		Type A	Type B	Identification of earth connection points visible? Yes <input type="checkbox"/> No <input type="checkbox"/>	
Equivalent earth resistance, $\Omega$ :		Soil resistivity, $\Omega.m$ :		Earth termination system visible: Yes <input type="checkbox"/> No <input type="checkbox"/>	
Connection between DTS and ATS:		Connections acceptable <input type="checkbox"/>		Connections needed refastening <sup>a</sup> <input type="checkbox"/>	Connections needed to be replaced <sup>a</sup> <input type="checkbox"/>
Safe dispersing of lightning current:			Yes <input type="checkbox"/>		No <input type="checkbox"/>
<sup>a</sup> In the event of connections that were refastened or replaced, please provide a drawing that shows the locations of these connections.					

Amdt 1

**UMHLAHLANDLELA WOKWAKHIWA KOPHAHLA  
LOTSHANI ENINGIZIMU AFRIKA**

Amdt 1

<b>4.4 Lightning equipotential bonding</b>			
Equipotential bonding bar inspected:		Acceptable <input type="checkbox"/>	Replaced <sup>b</sup> <input type="checkbox"/>
System connected to bonding bar:	Telecommunication <input type="checkbox"/>	Pipes <input type="checkbox"/>	Electrical <input type="checkbox"/> Equipment, describe:
Material used:	Steel (stainless or galvanized) <input type="checkbox"/>	Copper <input type="checkbox"/>	Connection between bonding bar, ETS and DTS: Acceptable <input type="checkbox"/> Repaired <sup>c</sup> <input type="checkbox"/>
Surge protective devices inspection:	Acceptable <input type="checkbox"/>	Damaged (reported to electrician) <input type="checkbox"/>	
Bonding of metal equipment checked:	Pipes <input type="checkbox"/>	Conduit <input type="checkbox"/>	Gutters <input type="checkbox"/> Roofs <input type="checkbox"/>
<b>5. Approval signature</b>			
Name of lightning protection inspector:		Company:	
Tel No.:		Date:	
ID No.:		Signature:	
NOTE The following abbreviations have been used:			
ATS air-termination systems			
DTS down conductor termination system			
ETS earth-termination system			
<sup>b</sup> In the event of an equipotential bonding bar that was replaced, proof of correct installation and reconnection of equipment to the bonding bar shall be shown.			
<sup>c</sup> In the event where the connection between the bonding bar, the ETS and the DTS was repaired, proof of the repair by accredited personnel shall be submitted.			

Amdt 1



# UMHLAHLANDLELA WOKWAKHIWA KOPHAHLA LOTSHANI ENINGIZIMU AFRIKA

## IZIBAMBINHLANSI

Isibambinhlansi esiyisibopho esiyimeshi esenziwe ngensimbi emenezelayo esifakwe ngaphakathi kukashimula ngaphakathi nobunzulu obuwbuncane obungama-700.

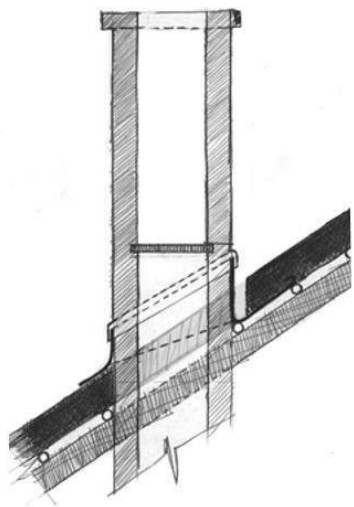
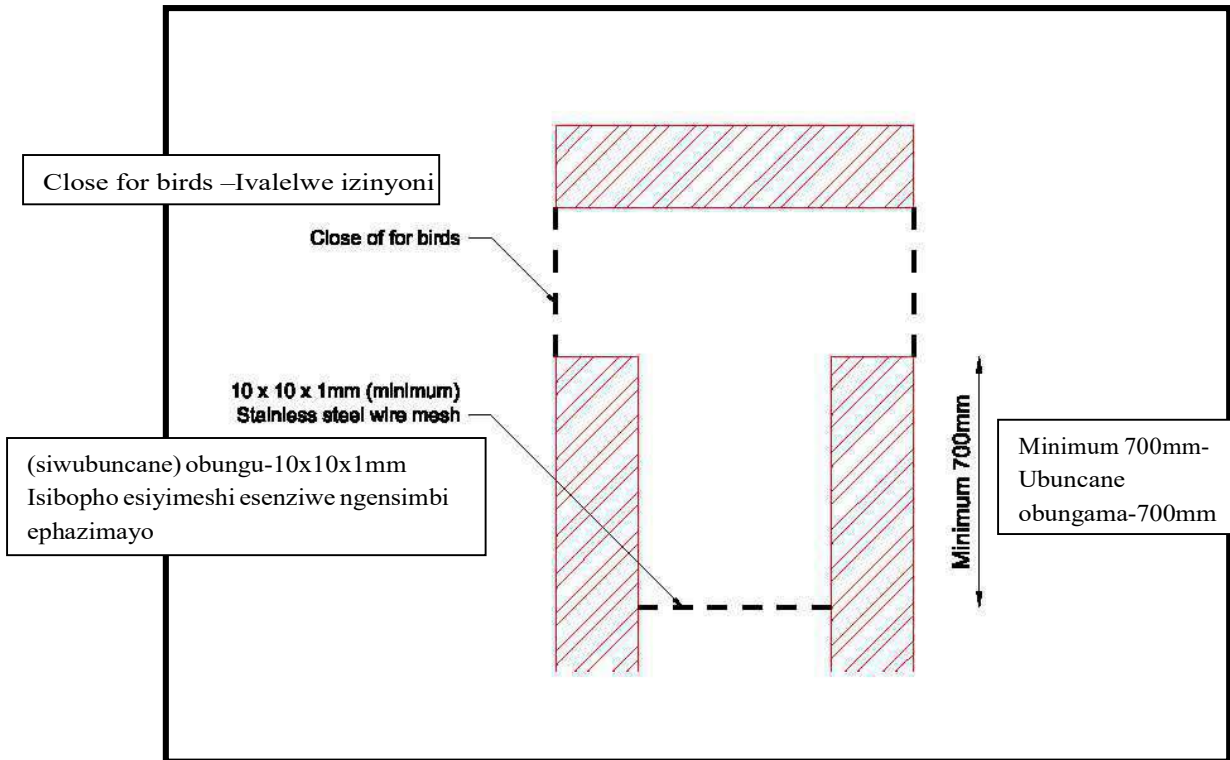

Isikhundla Esijwayelekile  
Sesibambinhlansi.

Kuphakanyiswa ukuthi oshimula bahlanzwe/bashanyelwe okungenani kanye ngonyaka ngaphambi kwesikhathi sonyaka sasebusika.

# UMHLAHLANDLELA WOKWAKHIWA KOPHAHLA LOTSHANI ENINGIZIMU AFRIKA

---

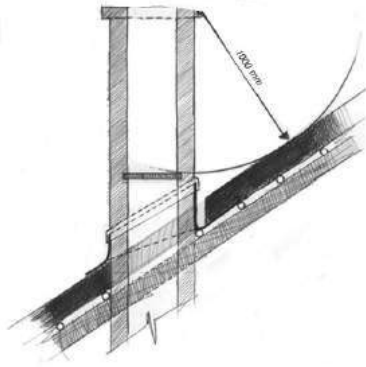

Isigaba esijwayelekile esiphuma ngaphakathi kukashimula esibonisa ubude obuwbuncane ngaphezu kwengqimba yotshani bokufulela, engama-1000 mm njengoba kubekwe Ngumthetho Wokwakha Kuzwelonke.

## IZINHLELO ZOKOKUNETHISA

Eyodwa yokwenziwayo okungcono kakhulu ukuvimbela imililo ukuthi yande ngaphakathi nophahla olwakhiwe ngotshani ukufakwa kwezinhlelo zokunethisela phansi amanzi engxenyeni ephakeme kakhulu yophahla. Uhlelo lokunethisela phansi amanzi olwenzelwe loko lwehlisa amanzi ngaphezu luphinde luwashonise phansi kulo lonke uphahla oluvelile uma nje kwenzeka ukuthi kube nesehlakalo somlilo. Noma loku kungeke kusindise indlu lapho umlilo uqalisa khona, kungavikela ukwanda komlilo ukusuka ophahleni ukuya kolunye.

Uhlelo olusebenza ngokuzenzakalelayo noma olwenziwayo lungafakwa. Izinhlelo ezisebenza ngokuzenzakalelayo zibandakanya okuzwela intuthu okusunduzela okokunethisela phansi ukusuka emlilweni ngaphakathi kwendlu yokuhlala. Ezindaweni lapho amandla omfutho wamanzi angenawo amandla kakhulu amaphampu angafakwa noma amanzi angaphantshwa ukusuka kumadamu okubhukuda asemakhaya.

## ISIVIMBELAMLILO

Ingubo eyisivimbelamlilo yindwangu etholwe kwamanye amazwe, ekwazi ukuvimbela amazinga okushisa angaphezu kwama-750 *degrees centigrade* esetshenziswayo. Le ndwangu iyalukwa ngokuqhubekayo ukuphambanisa yonke indawo ewuphahla lotshani bese ivalwa ngokuphelele ngotshani lophahla, ngakho-ke ayibonakali nhlobo. Kuphakanyiswa ukuthi okokwenza kokwakha kokubopha okuwukhethe kunokusetshenziswa kwentanjana yotiyela othungeleka ngokushesha ngakho-ke uyingozi maqondana nomlilo.

Ukusebenzisa ingubo yomlilo ophahleni olwakhiwe ngotshani kuyabhekisiswa yizinkampani zomshuwalense uma zibala amaphrimiyamu omshuwalense.

# UMHLAHLANDLELA WOKWAKHIWA KOPHAHLA LOTSHANI ENINGIZIMU AFRIKA

---

## AMANANI AMANDLA KAGESI

Ukwakhiwa kophahla lotshani kuyimboni ekhula ngokushesha eNingizimu Afrika njengoba sithola abantu abengeziwe befuna okunye ukwakha okwenziwa ngokwemvelo. Ngakho-ke njengoba lona kungumkhiqizo wophahla ongowemvelo ngokuphelele, ukwakhiwa kophahla lotshani kuyakhula kuba nedumela endaweni eyimvelo lapho amalungu omphakathi engeziwe ancikela maqondana nokokwenza kwemvelo okusetshenziselwa ukwakha, okwaziwa ngokuvamile “njengesifanekiso esiluhlaza” (“*green design*”).

Uphahla olwakhiwe ngotshani yilona oluwumkhiqizo wemvelo ongowusebenzisa ophahleni lwakho ngoba utshani butholakal ezweni futhi busetshenziswa ngaphandle kokwenziwa izinqubo ezithile ukuze kwenziwe isembozo sophahla sangempela. Ngenxa yamanani aphezulu okushisa kophahla lotshani asikho isidingo sanoma yinoma YIMUPHI weminye yemikhiqizo ukwakha okokubamba ukushisa.

Uma ubheka uphahla maqondana nomqondo “wobuluhlaza” uphahla olungcono kakhulu umuntu angalubeka phezu kwebhulidi uphahla lokwakhiwa ngotshani. Isakhiwo sakhiwe ngezinsika zokhuni ezigcina i-*CO2* kuso sonke isikhathi sempilo yebhulidi futhi uphahla lotshani nalo ngokwalo lungumkhiqizo wemvelo ogcina i-*CO2* okungokunye okuhle okwengeziwe. Loku okuwukuthi utshani bophahla buhlala iminyakanyaka. Uphahla lotshani kulindeleke ukuthi luhlale iminyaka eminingi okuyileso sikhathi ubuningi be-*CO2* bungakhishwa.

Ngokusebenzisa utshani bokwakha uphahla bufanekiselwa ukusetshenziswa esikhathini samanje kodwa futhi nokusetshenziswa ekuyingilizweni kwesikhathi esizayo. Ukwethembela kumikhiqizo eqine kakhulu kumthombo futhi okokwenza kuphinde kwehliswe. Uphahla lotshani lunobudlelwano obuhle nomhlaba, futhi bungokokwenza okuyingilizwayo. Abunayo ikhabhoni futhi kungokokwenza kwendawo futhi ngokusebenzisa umkhiqizo aseseki ngokwempela ukwakhiwa okunobudlelwano obuhle bemvelo kuphela kodwa seseka izinto zokwakha ezivela endaweni.

Ngenxa yokushisa okuhlasele umhlaba oyimbulunga, ukwehlukahlukana kwamazinga okushisa ngezikhathi zonyaka kuba okudlulele kakhulu. Imikhiqizo yokuvimba ukushisa ilethwa ezimakethe njalo nje kodwa uphahla lotshani luhlala njalo lungolomvelo kakhulu futhi luyisixazululo esinokuhlobana okuhle nemvelo. Ngokwezinzwa ngesisodwa sezinto zokuqedela ukwakha ezikwenelisa kakhulu. Awukho omunye umkhiqizo onalezi zimpawu ezimbili njengomkhiqizo oluhlaza. Ngenxa yamanani aphezulu ezimo sokushisa, ukulondolozwa kwamandla kagesi kuyaqinisekiswa, loku kwehlisa ukusetshenziswa kokushisa nokupholiswa kakhulu. Ngenxa yezinkulumo zezindleko zikagezi ezihlala zikhuphuka njalo kanye nokuba khona kokucima kukagesi kwesinye isikhathi, uphahla lotshani lukuthelela kakhulu ukulondolozwa kwamandla kagesi.

Izindleko eziphezulu kakhulu zophahla olwakhiwe ngotshani uma ziqhathaniswa nezophahla lwamathayili nazo ziyinkoleloze ebanjwe emaphrojekthini enziwe kungekudala. Uphahla

# UMHLAHLANDLELA WOKWAKHIWA KOPHAHLA LOTSHANI ENINGIZIMU AFRIKA

---

olwakhiwe ngotshani bufakaza ukuba nempumelelo enkulu kakhulu njengesembozo esifaka izinto eziningi eziyizindleko ezicatshangiwe. Uphahla lotshani aludini ukufakelwa okubamba ukushisa, izinhlelo zamagatha, ama-*fascia*, nama-*soffit*, amasilingi, ukupenda, njll. Futhi uphahla olwakhiwe ngotshani lunikeza isikhala sesilingi esengeziwe ngenxa yokuphakama okungama-45 deg, okunikeza ibhilidi umuzwa onamandla obukhulu. Uma zonke lezi zimpawu zicatshangwa uphahla olwakhiwe ngotshani ngeyodwa yezinkatho eziningi ezibiza kancane kakhulu zokuqedela uphahla ezimakethe.

Ukwakha ngotshani kusebenzisa izinto zokwenza ezitholakala ngokwemvelo, okusho ukuthi, utshani noma izintunga. ENingizimu Afrika, utshani bomdabu obuthile kuphele pbuvame ukusetshenziswa.

Kukhona izinzuzo eziningi zokusebenzisa uphahla lolwakhiwe ngotshani kunophahla olujwayelekile. Ukwakha ngotshani ukuvikela ukugeleza kokushisa ngokwemvelo kanye nensika yophahla engama-45 deg. Isikhala esengeziwe sobamba singakhiwe. Ezinye izinto zokwenza ezehlukile azidingeki uma usebenzise ukwakha uphahla lotshani olufana namagatha, amaphayiphi aqonde phansi, ama-*fascia*, ama-*soffit*, amasilingi, amakhonisi, ukupendwa kokokuqedelela okufana naloku njll. Uma unaka konke loku ukhetho lokwakha uphahla ngotshani ngolusemqoka kakhulu kanye futhi nokufaka iphuzu lokuthi wukhetho lokulondoloza amandla kagesi, kumele kube yisizathu esanele sabantu abengeziwe ukukhetha uphahla olwakhiwe ngotshani. Ingxenye yokubalwa okungenisiwe kumasipala yiloko okuzobalwa ngumqambizimo okubandakanya ukubalwa kwamazinga amandla kagesi okuhlukile.

Enye inganeko maqondana nokwakha ngotshani evamise ukubanjwa njalo nje izindleko zomshuwalensi. Ngenxa yezindlela ezihlukile zokufakela izinhlelo zokuvikela umlilo opahleni, umshuwalensi uyehliswa kakhulu yizinkampani zomshuwalensi.

Ngokuphathelene “nokuhlansa imvelo” umuntu udinga ukukhetha kakhulu izinxazululo zemvelo maqondana nezindlela kanye nezinto zokwakha. Akukho ukupholiswa okungenziwa ngobusuku obubodwa ukuze kubuyiswe ukuhlangezeka kwepulanethi, kodwa ngokukhetha nje uphahla lotshani umuntu usuke esesemzileni ofanele wokwenza umehluko.

## AMANANI AYISAMBA ESINCANE SIKA-R OKUBUNJANISWA KOPHAHLA

### UKULINGANISA UKUSEBENZA KWESIVIKELA KUGELEZA KOKUSHISA

Ukuvikela ukugeleza kokushisa kusho izinto zokwenza, noma inhlanganisela yaloko, ehlinzeka ukuvimbela ukugeleza kokushisa. Ukwazi ukuvikela ukugeleza kokushisa kwento yokwenza iyalinganiswa ekuhanjisweni kokushisa (u-k).

Ukuhanjiswa kokushisa okusezingeni eliphansi kulinganiswa nokwazi ukuvikela ukugeleza okusezingeni eliphezulu (inani lika-R). Ukusebenza ngempumelelo kwazo zonke izingxenye

# UMHLAHLANDLELA WOKWAKHIWA KOPHAHLA LOTSHANI ENINGIZIMU AFRIKA

---

kanye nezinhlelo zokushisa, ngaphandle kwamawindi neminyango, kwethulwa ngokuhambisana nenani u-R. Eminyango nakumawindi, ukusebenza ngempumelelo kwethulwa ngokuhambisana nenani lika-U.

## 1. INANI U-K: UKUHAMBISA UKUSHISA

Inani eliwu-K, noma ukuhambisa ukushisa, kuchazwa njengesimo sokokwenza esibona ukukwazi kwako ukuhambisa isivuvu ngaphakathi nomzimba wako ngaphansi kwezimo eziyisimo esingaguququki.

Inani eliwu-K lethulwa ngama- ngemitha ne-*Kelvin*:  $W/(m \cdot k)$

## 2. INANI U-U: UKUDLULISA UKUSHISA

Kwesinye isikhathi okokuvimbela ukushisa kulinganiselwa ngokuhambisana nokudlulisa ukushisa kwako (inani elingu-U), kunenani lako elingu-R. Inani elingu-U lilinganisaukudluliswa kokushisa ngokokwenza okuthile, ingxenye yebhildi noma ipheneli yokuhlanganisa (ukudluliswa kokushisa), kodwa inani elingu-R lilinganisa ukuvimbela maqondana nokudluliswa kokushisa. Amanani ka-U avamise ukusetshenziswa kwezemibhalo yobuchwepheshe, ikakhulukazi ukubonisa imithetho yokushisa yengilazi kanye nokubala ukulahlekelwa kanye nokuzuzwa kokushisa.

Inani lika-U ukuvumelana kwenani lika-R:  $u-R=1/U$  noma  $u-U=1/R$ . Ngokwesibonelo, ngenani lika-R elingu-2.0, inani u-U liba ngu- $\frac{1}{2}$  noma u-0.5.

Amanani ka-U ethulwa ngokusebenzisa amayunithi emethriki u- $(W/m^2 \cdot K)$  lapho:

- u-W usho isamba sokudlulisa ukushisa ukuphambanisa ubuso noma ngaphakathi kokokwenza ngama-watt;
- u- $m^2$  usho imitha eyodwa ephindwe kabili yokokwenza okunobuhlonzi obucacisiwe; kanye
- no-K noma 'idigri eyi-*Kelvin*' usho umehluko wesimo sokushisa se- $^{\circ}C$  ngayinye ukuphambanisa ebusweni bokokwenza noma ngaphakathi kokokwenza.

Inani elincane kakhulu elingu-U liba nomphumela wokugeleza ophansi, ngakho-ke liphinde futhi libe nokulahlekelwa wukushisa okuphansi. Amanani aphezulu kakhulu ka-U asho ukulahlekelwa ukushisa okukhulu kakhulu.

## 3. INANI LIKA-R: UKUVIMBELA UKUSHISA

Izinto zokwenza eziyizivimbela kushisa ziyalinganiselwa ngokusebenza kwazo ekuvimbeleni ukudluliswa kokushisa. Loku kwethulwa njengenani u-R, elaziwa futhi ngokuthi ukuvimbela ukushisa. Ngakho-ke, inani u-R isilinganiso sokuvimbela ukugeleza kokushisa kokokwenza okunikeziwe okuwubuhlonzi obuthile. Ngaloko-ke, inani elingu-R lingumhlahandlela maqondana nokusebenza kwako njengesivimbela kushisa: Uma inani lika-R liphezulu kakhulu, yilapho okokwenza kuba nokuvimbela ukushisa okwengeziwe (okusho ukuthi,

# UMHLAHLANDLELA WOKWAKHIWA KOPHAHLA LOTSHANI ENINGIZIMU AFRIKA

---

ukuvimbela ukugeleza kokushisa), futhi izohlinzeka ngokuvimbela kushisa okungcono kakhulu.

Amanani ka-R ethulwa esebenzisa amayunithi emethriki u-m<sup>2</sup>.K/W (amamitha aphindwe kabili e-*Kelvin* ku-*Watt* ngayinye) lapho:

- u-m<sup>2</sup> usho imitha eyodwa ephindwe kabili yokokwenza okunobuhlonzi obucacisiwe;
- u-K usho umehluko wesimo sokushisa esiyidigri eyodwa (i-*Kelvin* noma i-*Celsius*) ukuphambanisa okokwenza; kanye
- no-W usho isamba sokushisa okugelelza ngaphakathi kokokwenza ngama-watt.

Ukusuka emiphumeleni yombiko wokuvivinya i-*ASTM C 518-10* yi-*TTL* efakwe usuku lomhla ka-11 kuJuni ka-2013, inani lika-K lophahla lotshani ngu-:  
K = 0.056 W/(m.K)

Ubuhlonzi obudingekayo- (D(m)) ukuhlonipha i-*SANS 10400-XA* ngakho-ke:

INCAZELO	Indawo Yesimo Sezulu-1	Indawo Yesimo Sezulu-2	Indawo Yesimo Sezulu-3	Indawo Yesimo Sezulu-4	Indawo Yesimo Sezulu-5	Indawo Yesimo Sezulu-6
Isidingo Esiyinani Eliwubuncane-R (m <sup>2</sup> .K/W)	3.7	3.2	2.7	3.7	2.7	3.5
Ubuhlonzi obuwubuncane obudingekayo bophahla olwakhiwe ngotshani (ngama-mm)	207	179	151	207	151	196
Inkombandlela yokugeleza kokushisa	phezulu	phezulu	phezulu nabantu	phezulu	phansi	phezulu

$$D(m) = R(m^2.K/W) \times k(W/(m.K))$$

Kodwa, uma ngabe ukubalwa okungenhla kobuhlonzi kungaphansi kwesidingo se-*SANS 10407-2015* Sesihumusho sesi-2 bese okukhulu kwaloku okubili kuzosetshenziswa. Umehluko wobuhlonzi uzokuba nomthelela wamandla aphozithivi phezu kwebhilidi ngokuphelele.

Imibandela enelisa okushiwoyo ixhaswa yizindawo zesimo sezulu, ezibandakanya nezimo zezulu ezingamabhalubhu ezomile, ukushisa okungaguquki; ukuswakama kanye nengozi yokujija kwangasogwini oluseNingizimu.

# UMHLAHLANDLELA WOKWAKHIWA KOPHAHLA LOTSHANI ENINGIZIMU AFRIKA

## IZINDAWO ZESIMO SEZULU ENINGIZIMU AFRIKA

UMQONDOJIKELELE WEZINDAWO ZESIMO SEZULU		
Indawo	Incazelo	Izikhungo Ezisemqoka
Indawo-1	Ingaphakathi Elibandayo	Johannesburg, Bloemfontein
Indawo-2	Ingaphakathi Elilingeneyo	Pretoria, Polokwane
Indawo-3	Ingaphakathi Elishisayo	Louis Trichardt, Nelspruit
Indawo-4	Okulingene Okungasogwini	Cape Town, Port Elizabeth
Indawo-5	Okungasogwini Okuyithrophiki	East London, Durban, Richards Bay
Indawo-6	Okungaphakathi Okomile	Upington, Kimberley

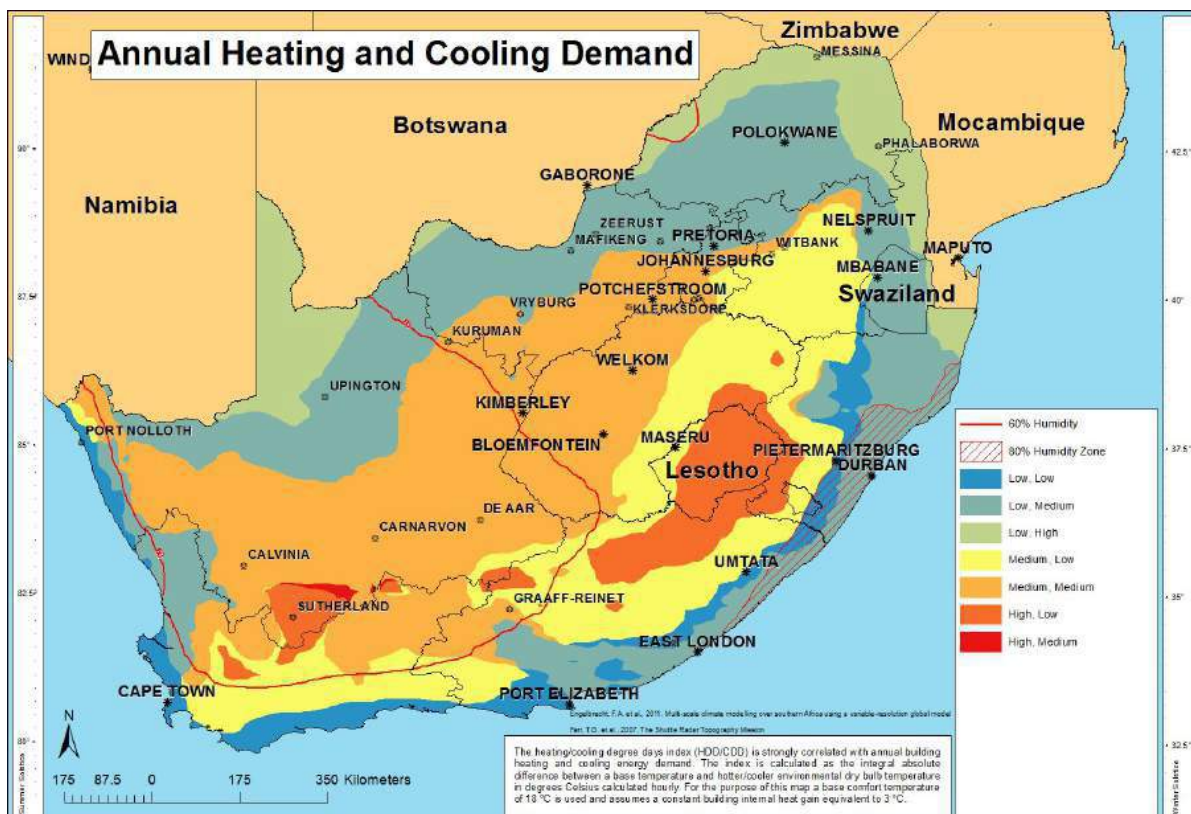

**UMHLAHLANDLELA WOKWAKHIWA KOPHAHLA  
LOTSHANI ENINGIZIMU AFRIKA**

Ukushisa Konyaka Ngonyaka kanye Nezimfuno Zokuphola

Indawo- 1	Indawo- 2	Indawo-2H	Indawo- 3	Indawo-e 4	Indawo- 5	Indawo- 5H	Indawo-e 6	Indawo- 7
Phakathi, Phakathi	Phakathi, Phansi	Umswakamo ongama-60%	Phansi, Phezulu	Phansi, Phansi	Phansi, Phakathi	Umswakamo ongama-80%	Phezulu, Phansi	Phezulu Phakathi
Aberdeen	Adendorp	Ashton	Bela Vista	Adelaide	Bathurst	Beacon Bay	Bergville	Frasersburg
Amalia	Alice	Caledon	Chokwe	Alexander Bay	Colenso	Durban	Cedarville	
Bakerville	Balfour	De Rust	Ellisras	Askraal	Delareysville	East London	Clarens	
Beaufort West	Bedford	Greyton	Giyani	Cape Town	Dibeng	Eshowe	Fouriesburg	
Bloemfontein	Belfast	Haarlem	Kakamas	Darling	Gaborone	Hamburg	Hofmeyer	
Brandvlei	Bethal	Laingsburg	Komatipoort	Dundee	Gobabis	Lusikisiki	Indwe	
Calvinia	Bohlokong	Montagu	Magude	East London	Groblersdal	Margate	Jamestown	
Citrusdal	Burgersdorp	Touws River	Macia	Elim	Groot Marico	Melmoth	Lady Grey	
Colesberg	Calitzdorp	Willowmore	Manhica	George	Hotazel	Ramsgate	Lesotho	
De Aar	Carolina		Maputo	Hawston	Keimoes	Sezela	Matatiele	
Douglas	Ceres		Messina	Heidelberg	Kirkwood	St. Lucia	Molteno	
Edenburg	Colenso		Mhlume	Hondeklipbaai	Klipplaat	Stanger	Sutherland	
Garies	Cradock		Phalaborwa	Imbali	Koster	Ulundi	Ugie	
Hartswater	Davel		Thohoyando	Jeffreys Bay	Leonardville	Uvongo		
Hoopstad	Eloff		Usakos	Kareedouw	Lobatse			
Jacobsdal	Emalahleni			Kleinmond	Mafikeng			
Johannesburg	Ermelo			Kleinsee	Makhado			
Kimberley	Estcourt			Knysna	Marydale			
Klerksdorp	Ezibeleni			Lamberts Bay	Mkuze			
Kuruman	Harding			Langebaan	Nelspruit			
Loeriesfontein	Kestell			Libode	Nongoma			
Loxton	Kokstad			Mossel Bay	Peddie			
Makwassie	Lindley			Oranjemund	Pofadder			
Merweville	Maclear			Parow	Polokwane			
Okiep	Marquard			Pietermaritzburg	Pretoria			
Orkney	Maseru			Pomeroy	Rehoboth			
Oviston	Memel			Port Elizabeth	Roedtan			
Parys	Moorivier			Port Nolloth	Slurry			
Postmasburg	Nigel			Riversdal	Stella			
Potchefstroom	Ogies			Saldanha	Swaziland			
Prieska	Rouxville			Strand	Thabazimbi			
Richmond	Umtata			Umzinto	Tzaneen			
Rietbron	Utrecht			Vredendal	Upington			
Rooiwal	Villiers			Vryheid	Vaalwater			
Sishen	Volksrust				Veldrif			
Springbok	Warden				Vioolsdrif			
Taug	Wepener				Warmbad			
Theunissen	Witbank				Weenen			
Trompsburg					Windhoek			
Venterstad					Witvlei			
Vryburg					Zeerust			
Welkom					Zibedelia			



# UMHLAHLANDLELA WOKWAKHIWA KOPHAHLA LOTSHANI ENINGIZIMU AFRIKA

Winburg							
Qaphela: Ukujiya kwendawo-2H kanye nokuswakama okuphezulu kwendawo-5H kumele kunakwe.							

## Isamba esiwubuncane samanani ka-R maqondana nophahla kanye namasilingi

1	2		3				4		5		6				7	
Indawo yamandla kagesi																
	1		2				3		4		5				6	
					2H								5H			
Ukushisa kanye Nokuphola	H	C	H	C	H	C	H	C	H	C	H	C	H	C	H	C
Phansi Phakathi, Phezulu	M	M	M	L	M	L	L	H	L	L	L	M	L	M	H	M
Isamba Esiwubuncane samanani adingekayo sika-R- (m <sup>2</sup> .K/W)	3.7		3.7		2.7		3.7		3.7		3.7		2.7		3.7	
Inkombandlela yokugeleza	Phezulu		Phezulu				Phansi		Phezulu		Phansi				Phezulu	
Qaphela: Ukujiya kwendawo-2H kanye nokuswakama okuphezulu kwendawo-5H kumele kunakwe.																

## ISIPHETHO

Ukwenza uphahla lotshani ngumkhakha okhethekile Kanye nokuhlala okuwubuciko kanye nokwenziwa komsebenzi kusemqoka ukuqinisekisa iphrojekthi enempumelelo.

- *I-Thatchers Association of South Africa (i-TASA)* ikhona ukusiza umphakathi kanye nabaqambizimo, onjiniyela kanye namanye amaphrofeshinali uma ngabe unanoma yimiphi imibuzo.

## UKUBONGA KANYE NAMAREFERENSI

### KWABAKWA-SABS

Ukwakhiwa kophahla lotshani: *SANS 10407 - 2015* Isihumusho sesi-2

Leli zinga libandakanya isifanekiso sesakhiwo sokweseka uphahla lotshani Kanye nokwakhiwa kophahla lotshani ezakhiweni zophahla lotshani.

QAPHELA I-*SANS 10400-L: 2011* Isihumusho se-3 libandakanya isifanekiso sezakhiwo zophahla, i-*SANS 10400-T* eyengamela izidingo zokuvikela umlilo, Kanye ne-*SANS 10400-V* eyengamela izidingo zeshimula. I-*SANS 2001-CT2* eyengamela ukwakhiwa komsebenzi wepulangwe ophahleni.

Imibhalo elandelayo eyenziwe amareferensi ayikwazi ukungalandelwa maqondana nokusetshenziswa kwalo mbhalo. Maqondana namareferensi afakwe usuku, yizihumusho ezishiwo ezisebenzayo kuphela. Maqondana namareferensi angafakiwe usuku, isihumusho sokugcina sombhalo oyireferensi (esibandakanya yinoma yiziphi izichibiyelo) esizosetshenziswa. Ulwazi olumaqondana namazinga kazwelonke Kanye nawamazwe ngamazwe lungatholakala Kudivishini Yamazinga Yase-*SABS*.

SANS 457-2, Wooden poles, droppers, guardrail posts and spacer blocks – Part 2: Softwood species.

SANS 457-3, Wooden poles, droppers, guardrail posts and spacer blocks – Part 3: Hardwood species.

SANS 820, Mild steel nails.

SANS 1083, Aggregates from natural sources – Aggregates for concrete.

SANS 1288, Preservative-treated timber.

SANS 1707-2, Sawn eucalyptus timber – Part 2: Brandering and battens.

SANS 1783-4, Sawn softwood timber – Part 4: Brandering and battens.

SANS 2001-CT2, Construction works – Part CT2: Structural timberwork (roofing).

SANS 10005, The preservative treatment of timber.

SANS 10155, Accuracy in buildings.

SANS 10183-1, Adhesives for wood – Part 1: Terminology.

SANS 10183-2, Adhesives for wood – Part 2: Requirements for structural applications.

SANS 10400-B, The application of the National Building Regulations – Part B: Structural design.

SANS 10400-K, The application of the National Building Regulations – Part K: Walls.

# UMHLAHLANDLELA WOKWAKHIWA KOPHAHLA LOTSHANI ENINGIZIMU AFRIKA

---

SANS 10400-L, The application of the National Building Regulations – Part L: Roofs.

SANS 10400-T, The application of the National Building Regulations – Part T: Fire protection.

SANS 10400-V, The application of the National Building Regulations – Part V: Space heating.

SANS 50197-1/EN 197-1, Cement – Part 1: Composition, specifications and conformity criteria for common cements.

Umbhali Wokuqokethwe Okusemqoka kanye Nezithombe:

**Ngu-JOHN SMITH**

**Translated from English to isiZulu by:**

**Mrs Nomadlozi Brenda Bokaba (Nee Sibeko)**

Lecturer isiZulu (University of Pretoria)

Ulwazi olwengeziwe kanye Nezithombe kunikezwe:

**NGAMALUNGU E-TASA**

**“UMHLAHLANDLELA WEZENZO EZINHLE ZOKUFULELA  
NGOTSHANI”**

Ishicilelwe Yidivishini yeZobuchwepheshe Bokwakha kanye Nokwakhiwa (*i-Building and Construction Technology*)

CSIR, PO Box 395, Pretoria, 0001

Ilungelo lokushicilela ngele-CSIR

© 1998, CSIR, Pretoria

Umbiko we-Boutek weno-bou/e9806

**I-SAWPA**

Ungaligubhela kanjani ugodo/ipholi

**I-TIPSASA**

Ukulinganisa Ukusebenza Ngemfanelo Kokuvimbela Ukugeleza Kukagesi

## UKULANDULA

Bonke ophahla abakhiwe ngotshani kudingeka ukuba bahloniphe i-SANS 10407: sika-2015 Isishicilelo sesi-2 esilinganisiwe esiphathelene nokwakhiwa kophahla lotshani. Kumele yakhiwe ngokuhambisana nezinhlalo zokwakha ezifanekiselwe futhi zavunyelwa ngunjiniyela oyiphrofeshinali obhalisiwe nonekhono. Ukuvunyelwa okusemthethweni kumele kubonakale ngokucacile nemidwebo eyisifanekiso Kanye nokulandelayo kumele kusayinwe ngokomthetho ngumuntu onekhono.

Emva kokuqeda ukwakhiwa kophahla lotshani, umuntu oneziqu noma onekhono kumele aqinisekise ukuthi isakhiwo sihlonipha izilinganiso ze-SANS 10407, ukuthi yenziwe ngokuhambisana nemidwebo kanye nokuthi iziqu zokwenziwa komsebenzi ngezazinga lobuphrofeshini.

I-TASA ayikwazi ukubophezelwa maqondana nanoma yisiphi isakhiwo esinephutha, ukwehluleka kwesifanekiso, umsebenzi owenziwe budedengu noma ukulimala okuba nomphumela okungaba ngumphumela oqondile noma ongaqondile waloku okungenhla.