

A GUIDE TO THATCH CONSTRUCTION IN SOUTH AFRICA



**THATCHERS ASSOCIATION OF
SOUTH AFRICA**

A GUIDE TO THATCH CONSTRUCTION IN SOUTH AFRICA – 2016 Edition 1

This document is a must for Owners, Thatching Contractors, Building Contractors, Architects, Decision Makers, Engineers and Certification Bodies.

For further information on the material in this guide, please contact:

Thatchers Association of South Africa

Private Bag X 1015

Lyttelton

0140

South Africa

+27 (0)83-283-8429

admin@sa-thatchers.co.za

ALL RIGHTS RESERVED

This Guide to Thatch Construction in South Africa is a publication of the Thatchers Association of South Africa and is not a specification. The Specification for Thatch roofs is SANS 10407 – 2015 Edition 2

This Guide is the property of the Thatchers Association of South Africa and no part of this publication may be removed or changed or added except by the majority decision of the Executive Committee of the TASA.

FOREWORD

The Thatchers Association of South Africa (TASA) developed this document to meet the growing need for definite guidelines on the erection and maintenance of thatched roofs of a quality in compliance with the requirements of the different South African National Standards

Compliance with minimum standards is a necessity. This practical guide explains the material, processes and test methods to be used in order to comply with those requirements

This document compliments the National Building regulations as well as SANS 10407 – 2015 Edition 2. We can expect these standards to become compulsory in the near future. This document will assist the industry to prepare for this.

More important, this document will also create a sense of confidence in the industry. End users and Thatchers will be able to use this as a reference document supporting the National Standards.

This became extremely necessary as the level of competency of new incomers into the industry as well as the changing characteristics of the raw material have an enormous effect on the quality of the end product.

This document is a must for thatchers, building contractors, architects decision makers, engineers and certification bodies. TASA needs to be complimented for the effort and the completeness of this document which will contribute to a healthier and more reliable Industry by levelling the playing field.

We at SATAS are proud to be associated with TASA through Certification of its members. For us as a Certification Body it is important to be fair and consequent in our certifications and evaluations and these guidelines will also assist us to act in an impartial and fair way.

Congratulations and thank you to all who contributed to make this document an outstanding guidance document that will make a difference in the industry

Abe Stears
Managing Director
SATAS

SOUTH AFRICAN TECHNICAL AUDITING SERVICES (PTY) LTD
PO BOX 4443
RIETVALLEIRAND
0174



ACKNOWLEDGEMENT

The Thatchers Association of South Africa wishes to thank SAWPA (the South African Wood Preservers Association) for their sponsorship to finance the preparation of this guide.



CHOOSE THE CORRECT HAZARD (H) CLASS:

- H2 – Low Hazard:** Inside above ground
- H3 – Moderate Hazard:** Outside above ground
- H4 – High Hazard:** Outside in ground
- H5 – High Hazard:** Outside in contact with heavy wet soil or in fresh water
- H6 – High Hazard:** Prolonged immersion in sea water



FOR MORE INFORMATION ABOUT SAWPA MEMBERS
AND HOW TO CONTACT THEM. CONTACT:

Tel: 011 974 1061
sawpa@global.co.za
www.sawpa.co.za



ACKNOWLEDGEMENT



The only company
to specialise exclusively
in thatch insurance underwriting

Thatch Risk Acceptances was established on 1 July 1998 with the specific aim to service the diverse and demanding needs of the thatch risk market. We are an established firm in the insurance industry, with a proven track record, providing personal service and quick turn-around times through a team of knowledgeable, dedicated and friendly staff.

Telephone
086 110 5799

Website
www.tra.co.za

For further information, kindly contact your broker

Authorised Financial Services Provider FSP Licence Number 2317
Underwritten by Compass Insurance Company Limited FSP 12148

ACKNOWLEDGEMENT

TASA MEMBERS

CAPE REGION

Cintsa Thatching

082 780 5725

info@cintsathatching.co.za

Highveld Cape Thatchers

021 850 0779

info@highveldcapethatchers.co.za

Jason Lucas Master Thatchers

0817055014

info@jasonlucasmasterthatchers.co.za

Lucas Quality Thatchers

021 919 8397

info@lqt.co.za

Thatchscapes cc

021 9821234

info@thatchscapes.co.za

Theunissen Thatching

021 883 8383

tthatch@adept.co.za

GAUTENG

Con-Thatch (Pty) Ltd

011 958 1634

info@con-thatch.co.za

KWAZULU NATAL

Biggarsberg Thatchers

034 651 1664

thatchers@thatcher.co.za

LIMPOPO

Waterfront Pole & Thatch

014 736 4991

cobuswaterfrontthatch@gmail.com

MPUMALANGA

Hoffmans' Thatching Specialists cc

082 608 2053

david@hoffmansthatching.co.za

FREE STATE

Recon Thatchers

051 451 1291

nieuwenhuis@intekom.co.za

CONTENTS

	Page number
DEFINITIONS	10
PROJECT PROCESS	12
Requirements	12
Architects and Engineers	12
Thatching Contractors	13
Helpful Questions when Appointing a Contractor	14
Questions Insurance Companies might ask	15
Process to a Successful Project	16
Contractor Responsibilities	17
Client Responsibilities	17
THATCH DESIGNS	18
THATCHING MATERIAL	21
Thatching Grass & Reeds General	21
Thatching Grass Specification	22
Cape Reed Specification	25
Water Reed Specification	26
Storage of Thatch on Site	26
Cleaning & Bundling	28
THE ROOF STRUCTURE	29
Setting out of the Structure	29
Timber Requirements	32
Planting Posts	32
Upright Columns	34
King Posts	34
Rafter Spacing	36
Truss Spacing	36
Tie Beam Spacing & Positioning	37

A GUIDE TO THATCH CONSTRUCTION IN SOUTH AFRICA

Ring Beam Connections	37
Deflection	39
Wind Braces	40
Battens and Laths	41
Lath Spacing	41
Valleys	42
Hips	44
Verges	44
Chimneys	45
Steel Flue Pipes	46
Chimney Stacks	49
Thatch Rolls	49
THATCHING	52
Spray Layer	52
Thatch Binding	54
Binding Spacing	55
Wire Binding Tension	55
Twine Binding Tension	56
Sway	57
Thatching over Sways	57
Thickness of Thatch Layers	58
Laying of Thatch	59
RIDGES	60
General	60
Grass Ridges	62
Fibre Glass Ridges	62
Sand & Cement Ridges	63
GENERAL INSTALLATIONS	66
Flashing Installations	66
Bird Mesh Installations	66
Dormer Window Installations	67

A GUIDE TO THATCH CONSTRUCTION IN SOUTH AFRICA

Box Gutters	67
Thatch Façade	68
Ceilings in Thatch roofs	68
Geyser Installations	69
Site Safety	70
THATCH ROOF MAINTENANCE	71
THATCH ROOF REPAIR-OVER/RE-THATCH	74
FIRE SAFETY	76
Safety distances	76
Services	77
Use of Conductors	77
Lightning Protection System (LPS)	78
Lightning Ground Flash Density	79
Spark Arrestors	87
Drencher Systems	88
Fire blanket	88
ENERGY VALUES	89
Minimum Total R-Values of Roof Assemblies	90
Climate Zones in South Africa	92
CONCLUSION	93
ACKNOWLEDGEMENT AND REFERENCES	94
DISCLAIMER	96

DEFINITIONS

For the purposes of this guide, the following definitions apply.

Butt end

lower, cut end of a stem of thatch

Competent person

someone who has sufficient training, experience, knowledge and qualifications to assist adequately with a specific requirement

Deviation

difference between the actual (i.e. measured) dimension or position and the specified dimension or position

Dress

action of tapping the butt ends of thatch or thatching reed upwards with a leggatt to produce the correct surface slope

Lath

small round timber member, fixed parallel to the line of the ridge, at right angles to the rafters, and onto which thatch is fixed

Overlay

over thatch

second layer of thatch over original layer

Spray layer

layer immediately above the thatching battens or laths, where the underside will often be exposed in a room

Supporting wall

structural wall that functions as a load-bearing wall suitable to support a thatched roof

Sway

rod that is parallel to the lath in the thatch layer tie and binds material to the lath to secure the thatch

Rational assessment

assessment by a competent person of the adequacy of the performance of a solution in relation to requirements including as necessary, a process of reasoning, calculation and consideration of accepted analytical principles, based on a combination of deductions from available information, research and data, appropriate testing and service experience

Rational design (fire engineering)

design by a person who is registered in terms of the Engineering Profession Act, 2000 (Act No. 46 of 2000), as either a Professional Engineer or a Professional Engineering Technologist, and is generally recognized as having the necessary experience and training to undertake rational assessments or rational designs in the field of fire engineering

NOTE: This is a generic definition, to be used where no other definition is given, or no references are made to other standards. Other parts of SANS 10400 contain definitions of a more specific nature relevant to their disciplines.

PROJECT PROCESS

REQUIREMENTS

The building of thatch roofs and structures is a specialized trade. No matter how big or small the structure may be. The Regulations stipulates that a design and plan of what the structure will look like first needs to be drawn up by an architect or structural engineer. The design has to comply with Municipal and National Building regulations (SANS 10400-L and SANS 10407 (Thatched Roof Construction Specification)).

ARCHITECTS AND ENGINEERS

The architect will submit plans to the municipality as only a qualified and registered person with SACAP, South African Council of Architectural Profession, can submit plans. The registered home owner will be required to sign various municipal forms giving the architect permission to submit plans on their behalf. With each submission a copy of a property title deed is also required as basic submission requirements.

The plan must be approved by the Municipality and the structural engineer (competent person) has to inspect the structure again to verify whether it confirms to all the standards and regulations after completion. The engineer will then issue an A19 Certificate of compliance meaning the structure complies with all the standards and regulations. Without such a certificate the municipality will not sign off any structure for approval. The building inspector will also issue a Completion Certificate from the Municipality on completion when all requirements have been met. A property may not be bought or sold without this certificate.

Using a competent person also allows you to have a structure designed with all fire regulations in mind which benefits the home owner when it comes to insurance. Once proper fire protection methods are in place, insurance companies look at lower premiums benefitting the owner not only financially but also giving complete peace of mind. A competent person, someone registered in terms of the Engineering Profession Act, 2000 (Act No.46 of 2000), as either a Professional Engineer or a Professional Engineering Technologist, and has the necessary experience in the field of fire engineering, will also provide the Municipality with a Rational Design which is

A GUIDE TO THATCH CONSTRUCTION IN SOUTH AFRICA

often requested by the fire department within the municipalities, to show various calculations of how the thatch roof will not hold any risk to neighbouring buildings. The occurrence of bad workmanship, quality of materials used and absence of approved plans and not providing the above mentioned designs and certificates, tarnished the image of the Industry. Since the re-institution of TASA on 1 January 2006, two major determining factors for success or failure of a Thatching company came to the fore, namely:

1. Supervision on site by a knowledgeable person
2. Quality of material and workmanship

Thatched roofs built in the absence of approved plans and without the supervision of a qualified engineer caused headaches for clients and TASA. Bad workmanship, construction problems and inferior materials used provides enough evidence for a client to sue the contractor. Every thatched roof built in South Africa must be built according to the specification requirements of SANS 10407 – 2015 Edition 2 (Thatched Roof Construction) and SANS 10400 (National Building Regulations with special reference to part L)

It is in the client's best interest to ensure all the above mentioned requirements are met and to furthermore to enquire if the thatcher is registered with TASA as a member. By starting a Thatching project with this foundation, you are ensuring a successful outcome and a trouble free process.

THATCHING CONTRACTORS

Choosing a thatching contractor is a crucial step in the process. It is important to make sure the contractor is registered with TASA, Thatchers Association of South Africa. Thatchers registered with TASA all comply with the requirements and standards of a quality thatch roof. As mentioned, the thatch roof industry is a specialised field and choosing the cheapest contractor might be the most expensive mistake an owner can make.

There are basic principles unique to thatch roofs that need to be adhered to. To obtain the optimum life span from the roof, certain criteria, not obvious to non-specialists need to be followed such as roof angles, the position and angle of valleys relative to other features of the initial concept. The floor plan and elevations of the building affect the structural design of the roof often affecting the structural stability of the roof especially where there are varied ridge heights and roof junctions. These

A GUIDE TO THATCH CONSTRUCTION IN SOUTH AFRICA

junctions do not allow for the placement of effective bracing and very often there are no support walls to counter the lack of efficient bracing.

Given the above, the architect, at sketch plan stage, should consult with an authority in the industry to rectify or modify the design ensuring optimum stability of the structure and to maximise water runoff due to correct roof slopes and position of valleys in relation to the overall roof design.

To analyse a thatch structure the engineer will require a structural design of the proposed roof to calculate pole sizes and the number and diameter of bolts required for the varied connections.

Very often today thatch roofs are constructed without structural drawings and analysis and as a result are, after the fact, difficult and expensive to modify, sometimes impossible. With detailed drawings the architect can also assess the aesthetics of the structure and in conjunction with the engineer alter the detail to the benefit of the client.

HELPFUL QUESTIONS WHEN APPOINTING A CONTRACTOR

Whether the Contractor:

1. Is conversant with the SANS 10407 – 2015 Edition 2 Specification
2. Is conversant with the National Building Regulations
3. Is member of the Thatchers Association of South Africa
4. What is his membership number
5. Is the Contractor registered for VAT
6. How long has his firm been in operation
7. Has references from :
 - a. Architects
 - b. Engineers
 - c. Clients
8. Projects completed, Portfolio
9. Has the necessary infrastructure and trained staff
10. Will provide a written contract for the acceptance of both parties

A GUIDE TO THATCH CONSTRUCTION IN SOUTH AFRICA

11. Agree on who would be responsible to provide the necessary structural drawings, and building plans and arrange for the approval thereof by the relevant and appropriate authorities
12. Arrange for the required inspections and obtain the necessary and required clearance and engineering certificates
13. Who will take responsibility for insurance during construction
14. Does the contractor issue any guarantees on workmanship and materials.

QUESTIONS INSURANCE COMPANIES MIGHT ASK

Typical questions that an Insurance Company will ask:

- What is the name of your Thatching Company?
- What is the present condition of the roof?
- Has the building been rewired?
- Construction of the walls (brick & mortar, timber)?
- Does the kitchen have a concrete ceiling?
- Does the building have a chimney?
- If YES, does it extend above the roofline?
- Do you use open fires, fuelled by solid fuels (e.g. wood)?
- Are the chimneys fitted with spark arrestors?
- Does the building have an approved lightning conductor?
- Has the thatch been provided with a fire retardant system?
- Is the building protected by a drencher system?
- Is any fire fighting hose reels installed at the premises?
- Do you have a Certificate of Compliance from a competent or accredited source; or alternatively; an Engineers Certificate?
- What is the distance to your nearest Fire Station?

PROCESS TO A SUCCESSFUL PROJECT

1. Structural drawings or a plan drawn up by an Architect / Structural Engineer and approved by the appropriate authorities must be provided.

(Municipalities will not issue an occupation certificate without approved building plans and transfer of property will not take place in the absence of the above.)

- 1.1 In quoting for the project the Contractor must be well aware of what is expected and all specifications issued to him for calculating all quantities.
- 1.2 The Contractor must ascertain whether the drawings or design is in accordance with the regulations pertaining to a thatch roof.
- 1.3 The Contractor must comply with all requirements / specifications as determined by the structural engineer or architect so that a final certificate of approval can be obtained from them on completion of the project.

2. Specification

Construction must comply with the requirements of the SANS10407 – 2015 Edition 2

3. Written Contract

A written contract accepted and signed by both parties is a prerequisite before commencement of the project.

4. Complaints and Communication

- 4.1 Frequent and constructive communication between both Client and Contractor is encouraged.
- 4.2 Proper, complete and clear documentation regarding requests and alterations is of utmost importance throughout the project to avoid misunderstandings.

CONTRACTOR RESPONSIBILITIES

1. Effective and frequent feedback during progress.
2. Clients must be made fully aware of the work to be undertaken as well as specification and legal requirements.
3. Clients must be provided with a detailed document indicating the price as well as payment requirements. This includes estimates and written quotes.
4. Clients must also be provided with detailed time estimates as well as the expected date of completion. A complete timetable must be provided.
5. Clients must throughout be advised of any changes that may affect the proposed completion date and update the timetable accordingly.
6. The Contractor must accept responsibility for the actions of his workers/staff inclusive of sub-contractors, advisors or agents appointed by him.

CLIENT RESPONSIBILITIES

1. The client is to require all relevant approvals from authorities to avoid any delays.
2. Timely progress payments and final payment as agreed.
3. Co-operation and assistance as needed.

THATCH DESIGNS

Members of the South African Thatchers Association have constructed various creative designs and have proven that thatch can be so much more than the conventional designs. These are only a few examples.



Thatch is an aesthetically pleasing material medium



Note the Curved Rafters

A GUIDE TO THATCH CONSTRUCTION IN SOUTH AFRICA



Lathe Cladding to gable walls.



Creative and rustic way to hide bolts and nuts.

A GUIDE TO THATCH CONSTRUCTION IN SOUTH AFRICA



A Thatched Hotel



A thatch roof with rustic finishes.



Spectacular structure on a curved building with beautiful finishing.

THATCHING MATERIAL

THATCHING GRASS AND REEDS- GENERAL

In the Western Cape area treated South African Pine structures are built where in the rest of South Africa structures are built with Blue Gum/Eucalyptus.

The most commonly used South African grasses with their main geographical locations are listed below:

- *Hyparrhenia hirta* (generally known as common thatching grass) - Natal Berg area, in abundance;
- *Hyperphilia dissoluta* (commonly known as yellow thatching grass) - Northern Province, Mpumalanga, Northern KwaZulu-Natal and Swaziland;
- *Thamnochortus insignis* (or Cape thatching reed, commonly known as “dekriet”,) - Albertinia and Riversdale districts of the Cape;
- *Hyparrhenia dregeana* - Natal midlands and Berg area;
- *Hyparrhenia filipendula* (commonly known as fine thatching grass) - KwaZulu-Natal, Zululand coastal regions;
- *Thamnochortus erectus* and *Thamnochortus specigerus* (dekriet or thatch reed) – Cape coastal regions;
- *Chondropetalum tectorum* - Cape area, widespread; (**Not recommended**)
- *Phragmites australis* (Norfolk reed or swamp grass, known locally as Umhlanga grass) - widespread in South Africa. (**Not Recommended**)

Thatching materials, unless otherwise specified, must comply with the list of most commonly used grasses and reeds in South Africa and their geographical locations.

This means the thatch must be of a type that has a history of successful use as a roof covering in the relevant geographical locations and it has to be harvested at the time when growth has stopped, or the seed has ripened and dispersed.

Any application to the thatch and all fire retardant systems used, must not affect the lifespan of the thatching material, nor change the nature of the material prematurely.

Thatch should be stored in a manner to ensure no damage to the stem surface, clear from the ground and not unduly exposed to the weather.

THATCHING GRASS SPECIFICATION

Common or fine thatching grass (*Hyperrhenia Hirta* and *Hyperrhenia Phillependula*) for use shall:

1. Have a cut length of not less than 0,8m (measured from the butt end and including tips of seed ends)



Incorrect cut length of 0.75m



Correct cut length longer than 0.8m

2. Have a minimum diameter and maximum diameter at the butt end of 1,2mm and 2,5mm respectively;



Incorrect diameter of butt end: 1mm.

A GUIDE TO THATCH CONSTRUCTION IN SOUTH AFRICA



Correct diameter of butt end between 1.2mm and 2.5mm.

3. Be acceptably straight (cut above the first node);



Incorrectly cut below first node, see bent thatch. This will produce an unfinished surface on the exterior of your roof.



Correctly cut above first node

A GUIDE TO THATCH CONSTRUCTION IN SOUTH AFRICA

4. Be free of loose material;



Poor thatch uncombed at harvesting contains loose material



Properly harvested thatch free of any loose material

5. Must not be in the growing season;
6. Must be free of seed heads when cut.



Sample contains seed heads after being cut



Sample free of any seed heads at harvesting

CAPE REED SPECIFICATION

Thatching reed (*Thamnochortus* species) for use shall:

1. have a minimum cutting length of 1,0 m (measured from butt end and including tips of seed ends)
2. have a minimum diameter of 1,2 mm and a maximum diameter of 5 mm at the butt end;
3. be acceptably straight;

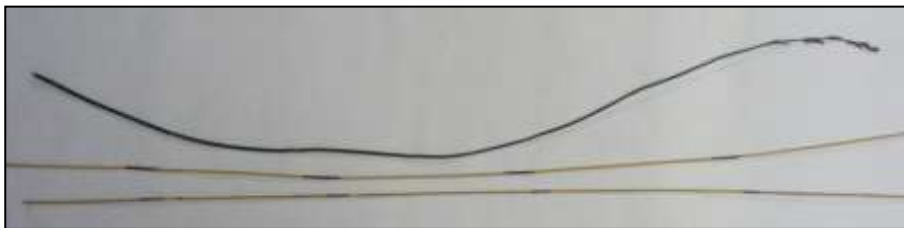

Sample not acceptably straight

4. be workable;
5. not be cut in the growing season (to ensure that the nodes are tight);



*This slide shows that this reed has been cut in the growing season
(therefore the nodes are loose)*



*Intact nodes cut out of the growing season
(Therefore nodes are tight)*

A GUIDE TO THATCH CONSTRUCTION IN SOUTH AFRICA

6. be mature and ligneous;
7. be free of sand and silt;
8. be sun-dried for at least 7 days before bundling.



*Cape reed wrong storage method
Full of seeds and leaves*



*Difference in quality of reed
Immature reed's color change*

WATER REED SPECIFICATION

Water reed (*Phragmites australis* or *Phragmites communis*) for use shall:

1. have a minimum length and maximum length of 1,5 m and 1,8 m, respectively (measured from butt end and including tips of seed ends)

STORAGE OF THATCH ON SITE

Thatching materials shall be stored such that:

1. the stem surface is not physically damaged,
2. the bundles are clear off the ground,
3. the bundles are not unduly exposed to moisture and the sun.

A GUIDE TO THATCH CONSTRUCTION IN SOUTH AFRICA



Incorrect storage of thatch grass on site



Correct storage of thatch grass on site



Good quality Cape reed stacked correctly

CLEANING AND BUNDLING

After the grass has been cut and loosely bundled, each bundle is shaken vigorously to dislodge all loose material. The bundles are then cleaned by passing a sickle through them, working from top to bottom. Grass bundles are between 75 and 100 mm in diameter. These bundles are each tied with a thong of twisted grass or with twine and packed in heaps.

Thatch bundles are approximately 75mm in diameter, tied with twine and stacked upright.

THE ROOF STRUCTURE

SETTING OUT OF THE STRUCTURE

When poles are planted it is critical to make sure your angles are at 90 deg. The easiest way to ensure this is by using the dimensions in the sketch below to ensure an accurate 90 deg corner.

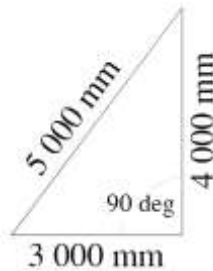

It is far easier to plot your hip and rafter layout on site by using your centre line of the building on the floor and marking all pole positions on this centre line and then making the same on the walls.

$$A = 6,100 \div 2 = B \ 3,050$$

$$\text{Hip position} = C \ 3,050 \text{ (same as B } 3,050)$$

D 7,800 is the total distance between hip positions.

To calculate rafter spacing $D \ 7,800 \div 900\text{mm}$ (max rafter spacing) = 8,666 gaps between rafters. (Always less but never more than 900mm),

Therefore $D \ 7,800 \div 9$ gaps = E 866mm spacing of rafters.

King post and truss calculated at no more than 2,700 in this case it is F 2,600.

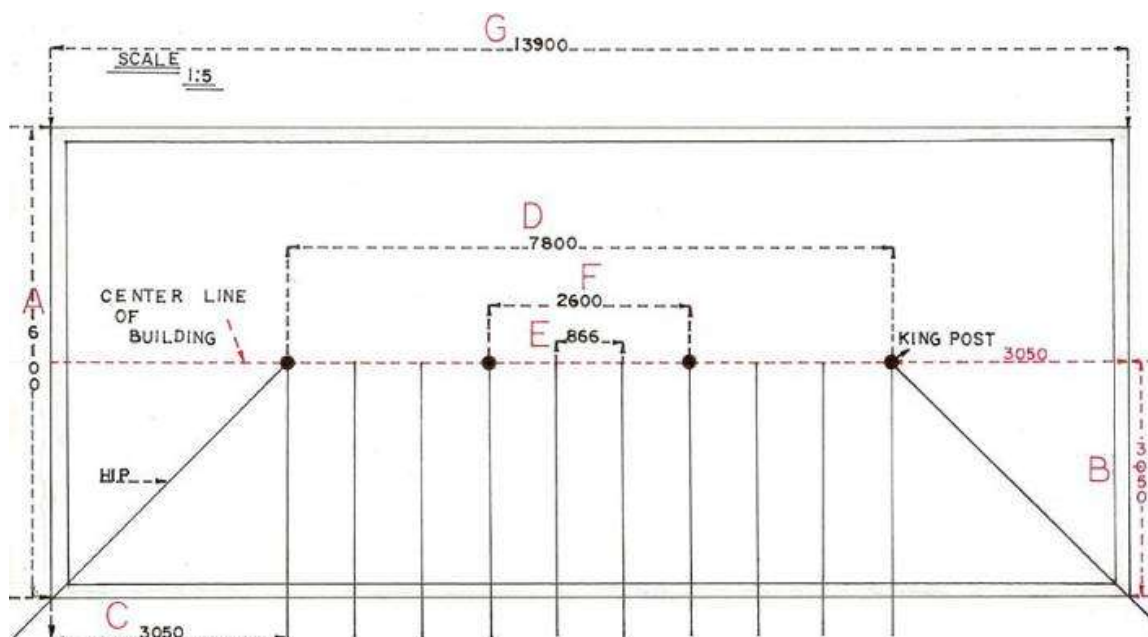

A GUIDE TO THATCH CONSTRUCTION IN SOUTH AFRICA

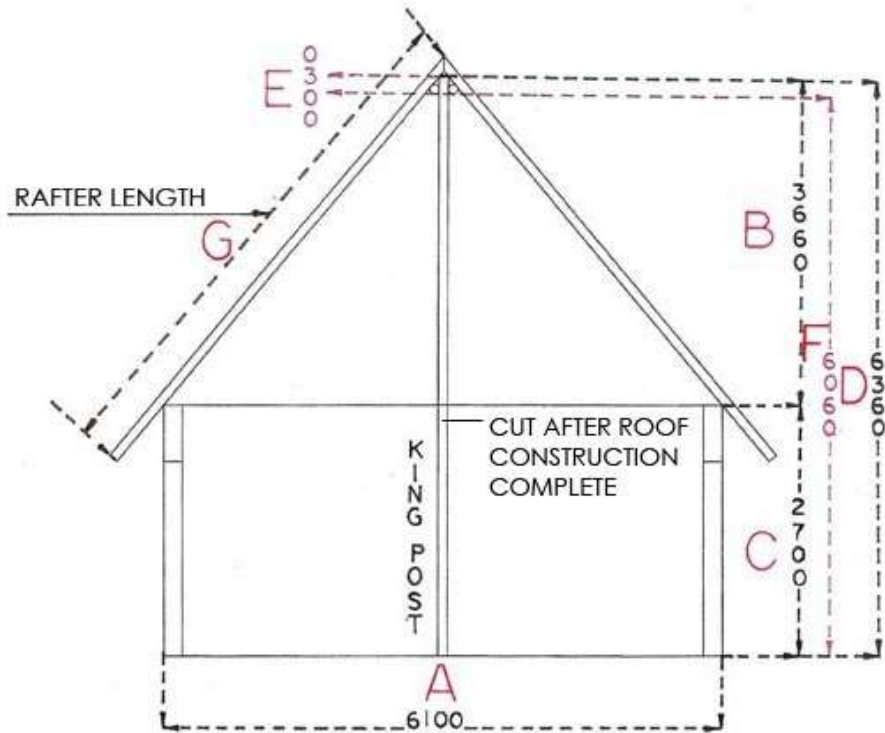

A thatch roof should have a minimum pitch of 45°. The steep slope is needed so that water will run off from the roof surface with minimum penetration into the body of the thatch coat. At a pitch of less than 45° the thatch will decay rapidly. Advantage may be taken of this steep pitch to utilise the roof space for an extra room.

To calculate the pitch length of a roof the factors below can be used depending on the angle of the roof. A = width, B = height, C = factor to calculate pitched length

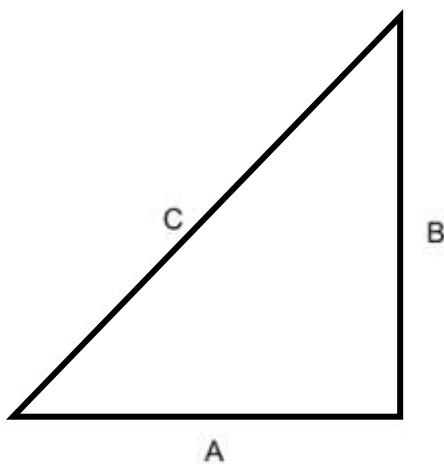

ANGLE	A	B	C
35 deg	1.000	0.700	1.221
40 deg	1.000	0.839	1.305
45 deg	1.000	1.000	1.414
50 deg	1.000	1.192	1.556
55 deg	1.000	1.428	1.743
60 deg	1.000	1.732	2.000

A GUIDE TO THATCH CONSTRUCTION IN SOUTH AFRICA

This problem is often caused by incorrect planning and lack of knowledge. If the correct length of poles are not calculated properly, shortcuts are going to happen i.e. dropping the height to accommodate short rafters. These pitch dials can be purchased from any hardware store and is inexpensive.



Incorrect Roof Pitch @ less than the required 45°



Correct Primary Roof Pitch @ 45° or more



Incorrect pitch for a thatch roof.



Correct pitch for a thatch roof.

TIMBER REQUIREMENTS

Timber poles shall comply with the requirements of SANS 457-2 or SANS 457-3, as relevant. Laths and battens shall comply with the requirements of SANS 1288, 1707-2 (eucalyptus), or SANS 1783-4 (pine), as relevant. All timber shall be preservative treated in accordance with the requirements of SANS 10005.

Poles for use as structural elements shall have a diameter of at least 100 mm measured at thin ends.

PLANTING POSTS

The science of treating timber properly provides for the preservative to be deeply impregnated into the sapwood thereby giving a deep envelope of treatment around the central heartwood. It is preferable that your treated timber is purchased in the size in which you intend to use it. If this is not the case and you subsequently cut the timber, you may expose the untreated heartwood of the timber.

It is important that to retain the integrity of the treatment that you liberally swab or brush a suitable preservative e.g. Creosote or CCA, into the cut surface. The cut end of a pole or plank shall not be the end which you plant into the ground. Rather use the other uncut end. Anti-split plates should be replaced if you cut off an end of a pole.

If timber, e.g. a treated post is planted in the ground it is essential that you allow for drainage of rainwater through the timber.

Any pole planted in the ground should be a minimum classification of H4.

If a treated pole is planted into the ground, it is essential to look at the drainage of rainwater.

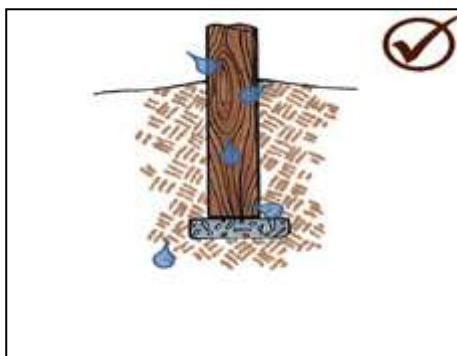

STAND: If a pole is planted on top of a concrete base make sure the base is completely dry before the pole is planted.

A GUIDE TO THATCH CONSTRUCTION IN SOUTH AFRICA

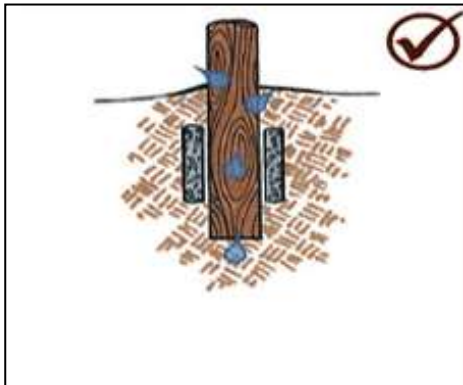

COLLAR: If concrete is used allow the concrete to form a collar with the pole protruding at the bottom to allow moisture to drain.

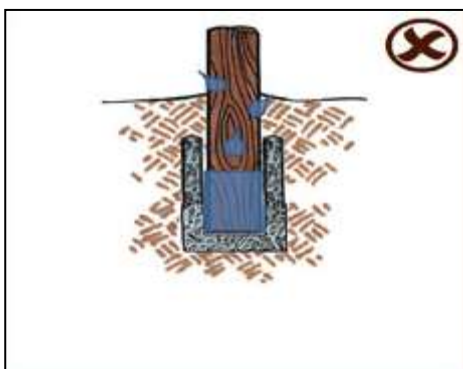

CUP: Do not allow the pole to stand in a closed bottom concrete base as it will rot in the moisture which cannot drain.

The details in these diagrams above assists proper drainage of any free moisture that may be absorbed by a wooden pole. A structural engineer must be consulted for detailed structural requirements in planting poles.

Do not enclose the planted end of the post in the concrete. If you need to use concrete then let the concrete form a collar around the post with the end of the post protruding through the concrete.

If you plant the post on concrete at the bottom of the hole, let the concrete set before planting the post.

The use and application of the correct H class of preservative treated timber will give you many years of satisfactory service which will be extended even further with proper maintenance.

UPRIGHT COLUMNS

Upright columns are to be spaced at no more than 3.5 meters apart and shall not be less than 175 mm (top diameter) or as specified by the Structural Engineer.

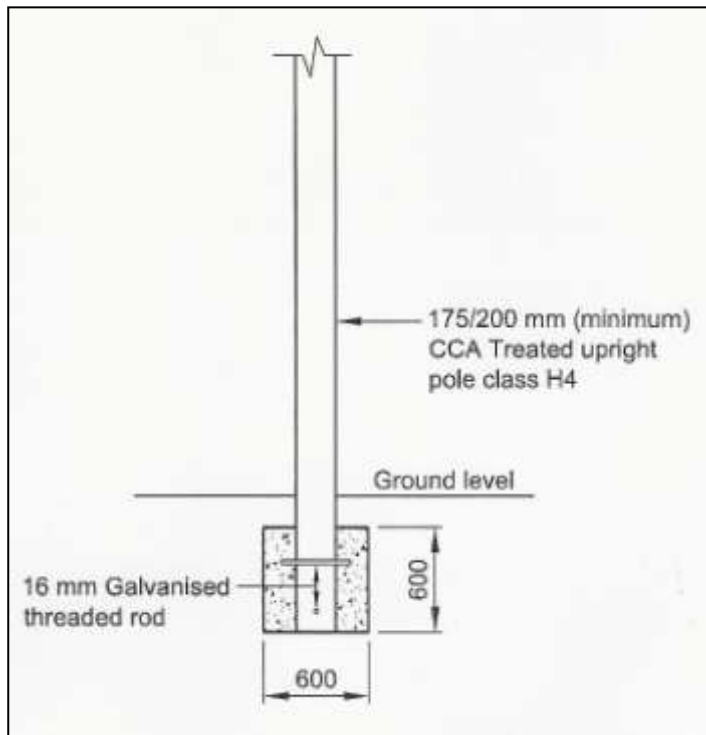

KING POSTS

All king posts are to have plum bobs attached at the top during the entire construction period. This will alleviate skew roofs.



Correct plumb bob position.



Incorrect plum bob position.

Uprights are not to be spaced more than 3.500 meters apart and minimum ring beam thickness to be not less than 150mm Ø on any building. As the building increases in width the ring beam thickness will increase (subject to engineer's approval).

Poles for use as rafters shall have a diameter of at least 100mm measured at the thin end of the pole.

RAFTER SPACING



800 mm
Correct rafter spacing, max is 900mm centre to centre



1 000 mm
Incorrect rafter spacing, shows more than the allowable 900 mm centres.

TRUSS SPACING



Intermediate Ringbeam
Trusses spaced correctly no more than 2.700m apart.

TIE BEAM SPACES AND POSITIONING



Span too great, showing deflection in the ridge pole

Totally inadequate tie beam spaces and positioning. Only one tie beam visible and no king posts.



Adequate tie beam and king posts.

RING BEAM CONNECTIONS

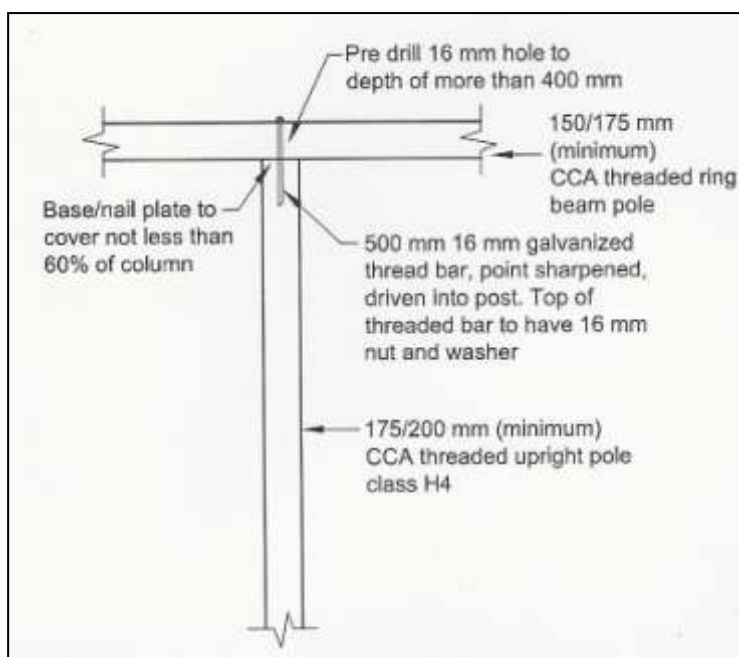

A GUIDE TO THATCH CONSTRUCTION IN SOUTH AFRICA

There are many ring beam failures and there are 3 main reasons:

1. The size of ring beam is too small.
2. The uprights are placed too far apart. (Where possible plan trusses above uprights).
3. No proper tie beams in place causing extra stress on the ring beam.



Shows example of bolting and connection of Ring Beam onto upright.



Improper ring beam connection to upright. Note only nails!



Shows an additional upright, which supports the lower ring beam.



Shows poor connection of ring beam to upright.

Minimum ring beam thickness to be not less than 150mm diameter measured at the thin end of the pole. As the building increases in width the ring beam thickness will increase (subject to engineer's design)

DEFLECTION



Ring beam with deflection.



Ring beam without deflection.

A GUIDE TO THATCH CONSTRUCTION IN SOUTH AFRICA



Shows no deflection on 14m pole. Long spans during construction need to be supported to alleviate deflection.



Deflection

Shows deflection. Caused by thin poles and loading before tie beams are in place.

WIND BRACES



Wind Brace

Shows wind brace support beams bolted to the underside of rafter poles.



Collapsed roof structure due to no wind brace supports.

BATTENS AND LATHS

Battens or laths shall be continuous over at least three rafters (i.e. a spacing of two rafters) and shall be fixed to every rafter that they cross. Battens shall be nailed to rafters with 75 or 100 mm wire nails. Care shall be taken not to split any of the members during the nailing process.

The ends of battens shall be sawn square and butt-jointed centrally over the rafter member. Joints in battens shall be arranged so that not more than one batten in any three is joined on any one rafter.

The battens and laths used shall have a minimum diameter of 38x38 mm and 25mm (top diameter) respectively and be spaced in accordance with the requirements for the respective types of thatching material used.

LATHS SPACING

Laths	Length of reed or thatch mm	Max laths Centres mm
First lath from batten	-	200
Second lath from batten	-	150
Second from top	-	150
All other battens	800, 1 200, 1 500	200, 300, 350

The maximum batten centre is determined by dividing the length of the thatch by 4.
Nails shall have a minimum diameter of 2.8 mm

A GUIDE TO THATCH CONSTRUCTION IN SOUTH AFRICA



As per the above table.



Incorrect spacing of laths as it exceeds max limit as shown in table above, also shows poor thatch finishing.

VALLEYS

Thatch valleys shall be formed by gradually orientating the thatching bundles in each layer from the normal vertical alignment direction to one that is parallel to the valley. Additional material shall be laid in the valley to provide extra thickness to prevent water penetration into the thatch layer and to provide a gradual sweep rather than a sharp bend.



Section through a grass valley showing the thickening of the thatching layer over the valley.

A GUIDE TO THATCH CONSTRUCTION IN SOUTH AFRICA

Valley liners are permissible using either galvanised (not suitable with Cape Reed), sheeting, aluminium sheeting, copper or brass valley liners are acceptable. Thickness of these materials should be no less than:

- 0.4mm for Copper sheeting
- 0.5 mm for Galvanised sheeting
- 0.7 mm for Aluminium sheeting



Valleys are the first to deteriorate in any thatch roof.



Valley liner being installed to the deteriorated valley.



Completed valley liner installation.

HIPS

Care should be taken when thatching roof hips to ensure that the grass bundles at the end of a hip plane run parallel to the hip rafter. On each side of the hip, as the course proceeds away from it, the bundles are gradually orientated until they are aligned perpendicularly to the battens. Care should also be taken to ensure that the full thickness of the thatch is maintained as it progresses around the bend of the hip. The density of the thatch layer on the hips tends to be lower than over the flat sections and additional thatch may be required. The thatch at the hips may require more regular maintenance because of accelerated weathering normally associated with low density. The use of two hip beams, one at each side of the corner, will provide an acceptable alternative to the problems caused by the 90° angle.

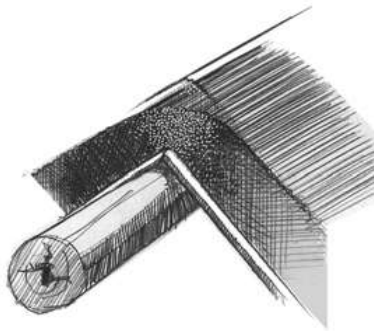

Section through hip showing a single pole and the thinner thatch layer over the corner.

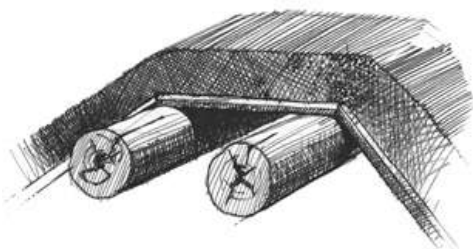

Section through hip showing a double pole construction with a thicker and denser thatch layer over a 135deg corner.

VERGES

The angle at which the bundles are laid, where eaves and verge join, should be maintained for the full sweep of the roof, up to ridge level.

CHIMNEYS

Chimneys shall be designed and built using only non-combustible materials with suitable insulation properties equal to that of a solidly built 200mm thick masonry wall unless based upon a rational design, prepared by a competent person.

The top of the stack must extend for a radius of at least one metre (measured from the top of the stack, closest to the roof covering) above the thatch covering of the roof. Securely build into the flue around the edges, or support on mild steel dowels, a spark-arrester consisting of a piece of 10 x 10 x 1 mm (minimum) stainless steel wire mesh, fitted 700 mm from the top, covering the full width of the flue.

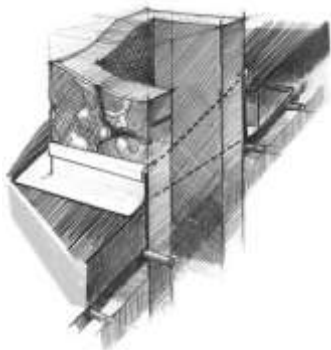

Cross-section through chimney, showing secret gutter and flashing details

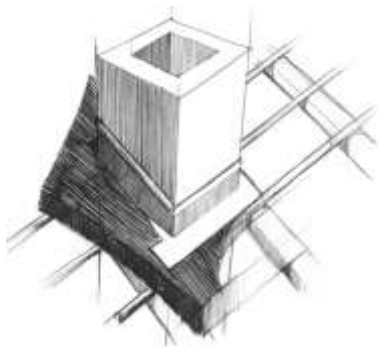

Preventing the thatch from sliding down

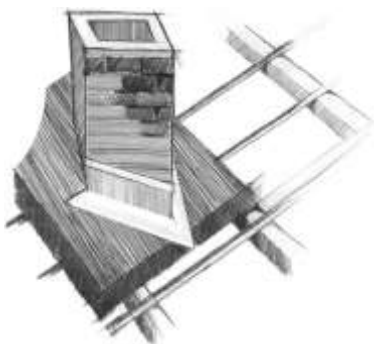

Alternative chimney detail to minimize water leaks.

STEEL FLUE PIPES

It is critical to ensure the flue pipe design and installation is one in such a manner that it will not cause a fire hazard to adjacent material. The flue pipe should not be connected to a shaft or duct which forms part of any ventilation system.

Where a chimney is provided with a flue lining, such lining shall be made of material which will withstand any action of the flue gases and will resist, without cracking or softening, the temperatures to which it might be subjected, and it shall extend throughout the full height of the chimney.



Alternatively the steel shutter box can be replaced using 20 mm shutter board.



Steel shutter box

6 mm Fibre Cement Board

Remove all loose thatch material before fire blanket is placed

A GUIDE TO THATCH CONSTRUCTION IN SOUTH AFRICA



1100 deg Fire blanket lining steel shutter box with fibre cement board base.

Fibre blanket wrapped at least 20mm up flue



Netting wire to be pulled over shuttered area before concrete capping is placed. Concrete capping chipped back to expose netting wire in capping.

50mm shutter for boxing mortar mix

Thatch tied back on itself, this ensures that birds are not able to pull loose thatch from under concrete capping.

A GUIDE TO THATCH CONSTRUCTION IN SOUTH AFRICA



6mm Fiber Cement board.

Note: All combustible materials cut back from flue by at least 230mm

Steel Shutter for Box fitted to laths by using screws.



Example of a correctly installed flue pipe.

CHIMNEY STACKS

Special care is required where elements such as chimney stacks and vent pipes penetrate the roof plane. Such features should be dressed/lined with a sheet metal or fibreglass reinforced polyester flashing under, between and over the top surface of the thatch. The width of the flashing should be at least 250 to 300 mm. In case of chimney stacks a secret gutter is then formed against the upper face of the chimney and flashed against it. The higher end of the sheet metal or fibreglass gutter is dressed up under the thatch to about 300 mm in width.

The side flashing (both sides of the chimney) will connect the upper flashing (under the thatch layer) with the bottom flashing (above the thatch layer), to allow the water to drain over the thatch surface. To prevent the thatch above and below the side flashing from sliding down, the thatch should be laid at an angle to secure the thatch to the laths adjacent to the flashing and at the same time also cover the side flashing.

The thatch layer should never be in contact with the top and the two sides of the chimney so as to allow water from the upper flashing to flow down. The thatch should be fixed around the chimney (the top and the two sides) to form a channel of at least 50 mm between the thatch and chimney.

Alternatively, to prevent any possible leak normally associated with chimneys, the buildings and/or roof should be such that the chimney stack always penetrates the roof at ridge level. Should this not be possible, the stack can be twisted by 45°, and not constructed parallel with the roof structure, thus eliminating the problem of creating concealed gutters and complicated flashings, etc, to allow water to run off without spilling over the flashings.

THATCH ROLLS

Nail Staples into ring beam spaced evenly between rafters allowing small gap to thread twine through staples and then around lath. Place thatch to form roll. Tie twine tightly, cut excess twine. Pull twine around to conceal knots behind lath. Cut rope to size and nail around rafter.

A GUIDE TO THATCH CONSTRUCTION IN SOUTH AFRICA

Thatch rolls can replace brick or mortar beam filling. Braided thatch rope to aesthetically enhance metal beams.



An example below of a beam filling finish using a thatch roll.



A GUIDE TO THATCH CONSTRUCTION IN SOUTH AFRICA



An example of rolled thatch gable ends.

THATCHING

SPRAY LAYER "SPREILAAG"

Before thatching proceeds, a layer of selected reed, cleaned thatching stems or Cape thatching reed, known as the *spray layer* (*spreilaag*), is spread evenly on the roof battens to a thickness of about 5 to 8 mm.

For grass a comb is made by driving a few 75 x 3.5 mm-diameter round wire nails into a horizontal pole about 300 mm long. The nails are spaced about 12 mm apart, in a straight line. The bundles of grass are placed across the top of the comb and pressed down so that the stalks are separated by the nails. The bundle is then pulled through the comb from the top to the bottom end.

A loose spray layer, cut to fit between the timber laths on the inside of the roof at ridge level, is used to finish off the ridge from the inside. If no spray layer of selected reed is used, it is recommended that ordinary clean thatching grass be used as a bottom layer to create a neat surface on the inside of the roof, (enough to conceal the top layer). This imparts an aesthetic appearance to the inside of the roof covering.

Thatch or thatching reed used in a spray layer shall be combed with a suitable comb to ensure that the stalks are clean before installation.

NOTE: A comb may be made by driving 75 mm wire nails into a horizontal pole. Bundles of thatch or thatching reed should be placed on top of the comb and pressed down so that the stalks are separated by the nails. The bundle should then be pulled through the comb from the top to the bottom end. Each bundle of thatching or thatching reed shall be butted against a butting board or level ground to ensure that the butt end is even and all sharp ends are blunted before installation.

A GUIDE TO THATCH CONSTRUCTION IN SOUTH AFRICA



Poor finish to spreij layer butt ends not concealed by batten or laths. Note loose binding twine.



Poorly finished, seed ends are visible.



Good example butt and seed ends are not visible. The butt ends are concealed. Twine is tight around the lath.



Neat finish to spreij layer

THATCH BINDING

The materials used shall be tar-treated sisal twine or stainless steel wire with a diameter of between 1mm and 1,2mm or galvanized wire with a diameter of 0.9mm. Stitching spaced at a maximum of 110 mm.

The binding or fastening of the thatch on the battens should be in accordance with the method of thatching used. And not be spaced more than 110mm apart. The materials used shall either be tar-treated sisal twine or stainless steel or galvanised wire with a diameter of between 0.9 mm and 1,2 mm.



Sisal tar twine binding



Wire binding

BINDING SPACING



*Incorrect binding spacing, greater than 110mm.
Note the loosely stitched twine.*



*Correct binding spacing at 110mm. Note the twine
is tightly around the lath*

WIRE BINDING TENSION



Loose wire is not tight around lath



Correct wire binding tension around lath

TWINE BINDING TENSION



Loose twine not tight around lath which will allow the layer of thatch to slide down.



Correct binding tension.

SWAY

Sways shall consist of either:

1. Galvanized wire with a minimum diameter of 3,15mm
2. Cape reed in bundles of at least 10mm.



Galvanised wire sway of min 3.15mm

THATCHING OVER SWAYS

The thatch cover over the sways depends on the type of material used and the thickness of the layer, and should be at least 40 % of the thickness of the specific layer. The minimum cover, however, shall not be less than table 2

THICKNESS OF THATCH LAYERS

The thickness of the finished layer for the respective thatching materials shall be as follows:

Species	Thickness of thatch layers (mm) Also subject to the thickness in table shown in SANS 10400 XA	Cover over sways or twine (mm)	Stem/butt diameter of individual reeds (mm)
Common or fine thatching grass	175	70	1,2 to 2,5
Thatching reed	180	80	2,5 to 4

Cover over sway.

The overall thickness of newly laid thatch may not be less than 175mm.



Functional thickness of thatch above sways not less than 70mm. (Cover over sway)

LAYING OF THATCH

Thatching shall commence from a verge at the bottom of the roof and shall be laid parallel to the rafters or trusses.

The thatching bundles at the end of the hip plane shall run parallel to the hip rafters. The full thickness of the thatch shall be maintained around the bend of the hip. Unless otherwise specified in the specification data, the thickness and minimum mass per square metre of the finished layer for the respective thatching materials shall be in accordance with the requirements.



Showing thatch bundles over laths during thatching process. Bundle length to span at least 3 gaps i.e.the tip must reach at least 4 laths.



This photo shows newly laid thatch, which has from the beginning been laid incorrectly. Note the distance from the binding to the butt ends. (Approximately 100mm). This incorrect laid thatch will shorten the lifespan of the roof.



The optimal length to ensure maximum roof life is 250mm to 300mm. This detail should carefully be monitored throughout the thatching installation. Care should be taken not to exceed the 300mm in common thatching grass, as it could be prone to wind damage.

RIDGES

GENERAL

The ridge construction shall be as specified in the scope of work.

1. Ridgepole construction must be either single or double ridge.
2. On both ridge constructions, the last two laths must be spaced at 150mm above your last line of thatch. This line must also be stitched down to secure the thatch in two places. It is also suggested that if cape reed is used as sways the last line of thatch should be fixed with a 3.15mm wire sway. This will ensure that the thatch is tightened properly without compromising the sway. Where the 3.15mm wire is joined, cape reed can be used as circuit breakers.
3. The last line must not be cut. The top ends of the grass must be folded over the ridgepole and fixed to the opposite side, covering the thatch on the hip end of the roof. The lath that was installed 300mm above the last line of thatch must be used to stitch down the opposite last layer of thatch.
4. This must be done from both sides of the roof.
5. The thatch on the hip end of the roof must be folded over the ridge pole and tied to the ridge pole and be stitched to the pole by means of a hook needle.



Note that the thatch has been cut at ridge and not bent over as required.

A GUIDE TO THATCH CONSTRUCTION IN SOUTH AFRICA



The bundles of ridging grass should be bent over the ridge and securely anchored by means of stitching onto the opposite two top most battens.

6. After the above has been completed all the thatch must be stitched to the ridgepole with a hook needle of scomple.
7. The above process is necessary to ensure that the last line of thatch does not slip out under the ridging. This process will also prevent birds from pulling out the thatch.
8. Before the ridge is installed the thatch and twine fixings must be rechecked to make sure that it is tight and that the last line of thatch is straight and in place.
9. In areas where birds are a problem, it is suggested that bird mesh with a hole diameter of no more than 25mm is placed over the last line of thatch and must extend at least 900mm from the center of the ridge down to the overhang. This bird mesh should also be stitched to the ridgepole to hold this in place, before installing the ridge over.
10. Different size roofs use different size ridging. Roofs up to a span of 4m use lapa ridging that is 700mm wide and can cover this size ridge with ease. Roofs that span between 4 and 10 meters should use a universal ridge which is 950mm wide. House ridging can also be used where roof are not at a 45 degree angle or have very wide span widths. The last two options are a matter of taste as both of the ridings can be successfully used.
11. Ridging should be used in as long as possible sections, to reduce the use of joins.
12. The ridging can now be fitted to the roof and the following must be taken in to consideration when fitting the ridge. Ridging should be placed loosely in its correct position and must be tightly stuffed with loose bundles of grass, the reason for this is to fill any void caused between the ridging and the thatch roof.

13. After the ridge has been stuffed the ridge can be pulled down onto the thatch. Every third wire must be pulled tight and tied to last lath, the wire must be stitched through the thatch at an angle as to eliminate the water flowing from following the fixing through the roof. By fixing it to the last lath, it is ensure that the fixing is under the ridging and cannot be effected by the water. The reason why only every third wire is fixed, is to hole the ridging in place while a spotter on the ground co-ordinates with the Thatcher, to aligns the ridge at the correct angle and level. (It is essential to use two thatchers, as it is impossible to install the ridge correctly if only one Thatcher is used.)

14. The installation of a rondawel or square cap is the same as a normal ridge with the exception being that the thatch is to be stitched to the king pole which protrudes a minimum of 200mm above the last line of thatch.

GRASS RIDGES

The bundles of ridging grass shall be bent over the ridge and securely anchored onto the two topmost battens with sways and a suitable method of binding or fastening.

FIBRE GLASS RIDGES

1. Fibre-glass ridging can be made in lengths of up to 9 meters.
2. 2 x 2mm Holes must be punched or drilled into the bottom 50mm reinforced part of the fibre-glass ridging.
3. It is suggested that the following be the minimum standard for raw material used to manufacture fiberglass ridging.
4. General purpose resin or resins deemed necessary by a competent person for a certain application.
5. A minimum glass content of 600grams per square meter.
6. The minimum glass to resin ratio must be 2:1.
7. The lowest 50mm of the ridging must be reinforced with an additional layer of 600 gram glass.
8. The ridge design must be of such a nature, that when installed the top of the ridge fits firmly on the ridge pole.
9. A minimum standard of FR202 resin must be used when manufacturing a fire retardant ridging.

SAND-CEMENT RIDGES

The ridge capping shall be a 40 mm (minimum) thick sand-cement ridge capping (one part common cement to four parts of sand), extending at least 750 mm from the ridge down each side of the thatching, laid on a single polyolefin membrane layer, reinforced with a galvanized metal lath or galvanized wire mesh, with a cover to the lath not less than 20 mm and suitably shaped and thickened at the ridge as shown in figure 2.

Lapping of joints in the polyolefin membrane shall not be less than 200 mm.

The materials in sand-cement ridges shall comprise

1. common cement that complies with SANS 50197-1;
2. sand that complies with the relevant requirements of SANS 1083;
3. galvanized wire mesh with a thickness not less than 0,8 mm and an opening that does not exceed 25 mm;
4. polyolefin membranes that have a thickness of not less than 250mm.

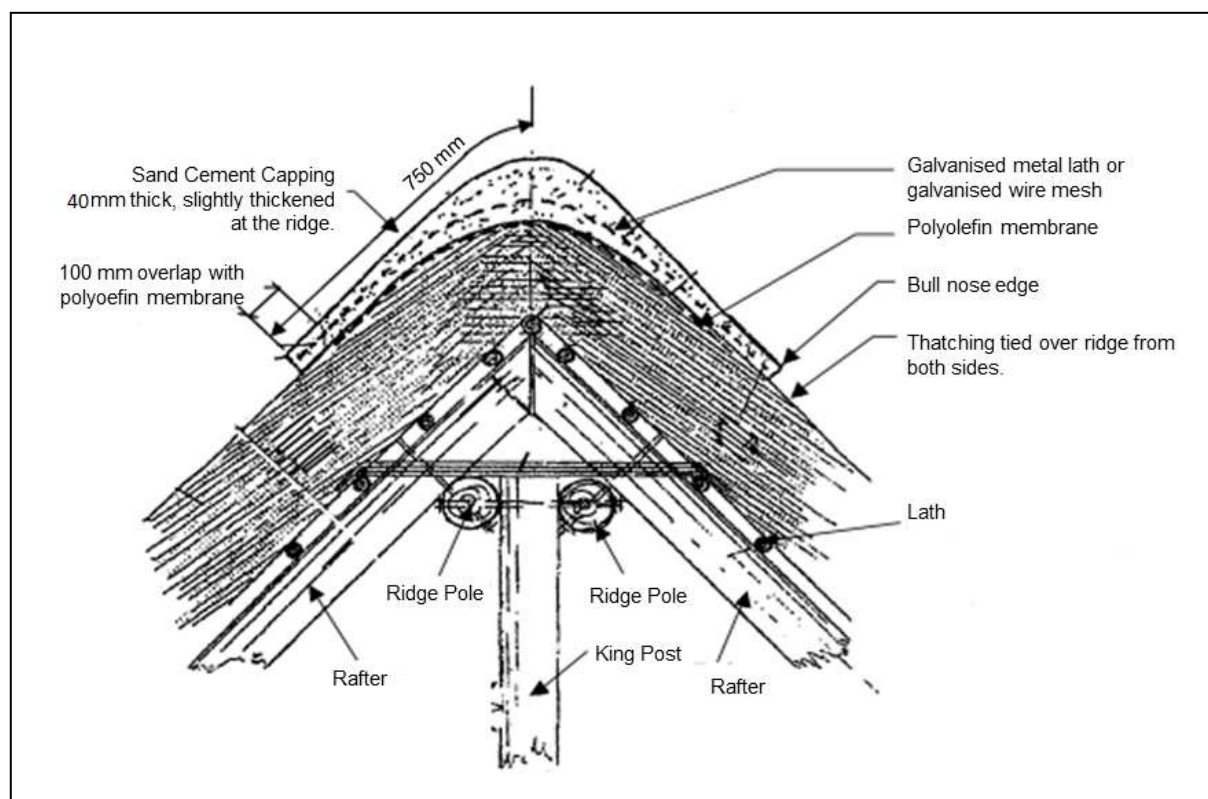

A GUIDE TO THATCH CONSTRUCTION IN SOUTH AFRICA



*Capping should have extended down to butt ends . (This detail does not apply to roofs thatched with Cape Reed)
Note Rotten Furrows marked in red.*

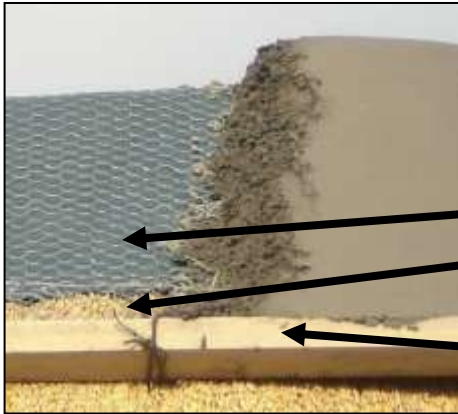

*Concrete must at all times cover the butt ends.
Maintain thickness of no less than 40mm over entire ridge.*

*Netting wire on 250 micron plastic.
100mm spacing between shuttering and start of plastic.
150 mm shuttering*

Mortar Mix: 2 wheelbarrows concrete sand to one bag Cement. 4:1 Ratio



Incorrect



Correct

A GUIDE TO THATCH CONSTRUCTION IN SOUTH AFRICA



Sprei Layer tied to laths prior to placing ridge capping.

Correct lower ridge capping. Note upward angle of concrete to discharge water.



Thatch over lower ridge capping not less than 150 mm.

GENERAL INSTALLATIONS

FLASHING INSTALLATIONS

Flashings frequently result in waterproofing problem areas. Features that intrude in the roof plane should consequently be avoided as far as possible.



Correct way to install flashings cut into wall and used silicon to seal spray grass under flashing plus minus 10mm thick and fit 200 mm thatch grass on top of flashing.

BIRD MESH INSTALLATIONS



*Correct way to fit bird mesh for baboons (maximum size of holes: 25 mm)
Bird mesh fitted around 'voetlaag' stitch around first batten with thin galvanize wire.*

DORMER WINDOW INSTALLATIONS

Dormer windows should be built at a minimum of 30 degrees. Dormer windows, set into the roof slope, and “eyebrow” windows at eave level should, for maximum thatch durability, be avoided. They invariably have a shallower pitch than the rest of the roof, so that the thatch above them decays at a more rapid rate.

Any installation less than 45 degrees will have higher maintenance than a roof of 45 degrees or more.



Correct installation of dormer windows.

BOX GUTTERS

It is preferable to not have valleys discharging rain water over the front door.



A steel box gutter was made to fit this problem area over a front door and concealed by using poles and laths.

THATCH FAÇADE

Old uninteresting buildings can be given a face lift by constructing a façade. Dull and uninteresting buildings can be enhanced with a thatch façade.



This photo was captured at the service entry to this hotel, showing the existing iron roof in place. Note the new aesthetic look to the building.

CEILINGS IN THATCH ROOFS

When using a ceiling in a thatch roof a spacing of 50mm should be kept between the laths and the ceiling. This allows enough “breathing space” to avoid condensation.

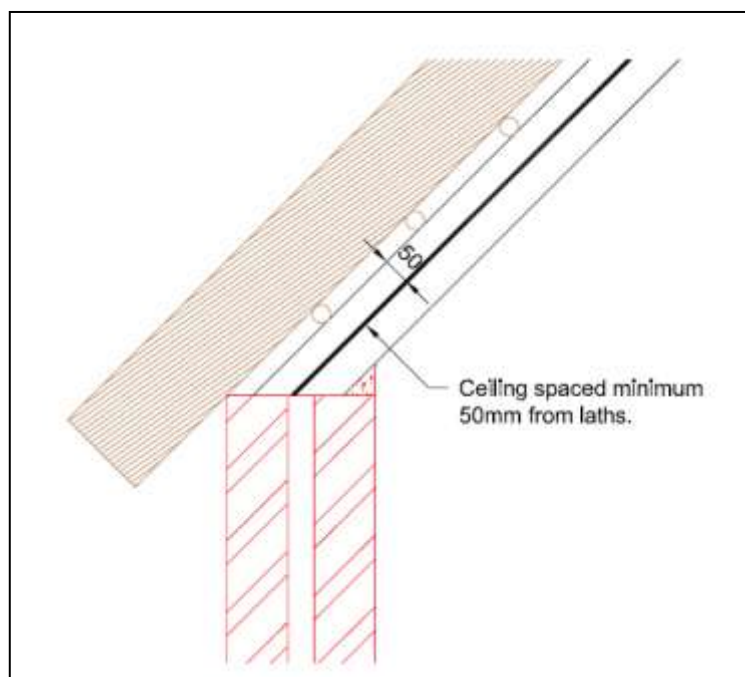

GEYSER INSTALLATIONS

The sketch below is a guide to how solar geysers and geysers should be installed onto thatch.

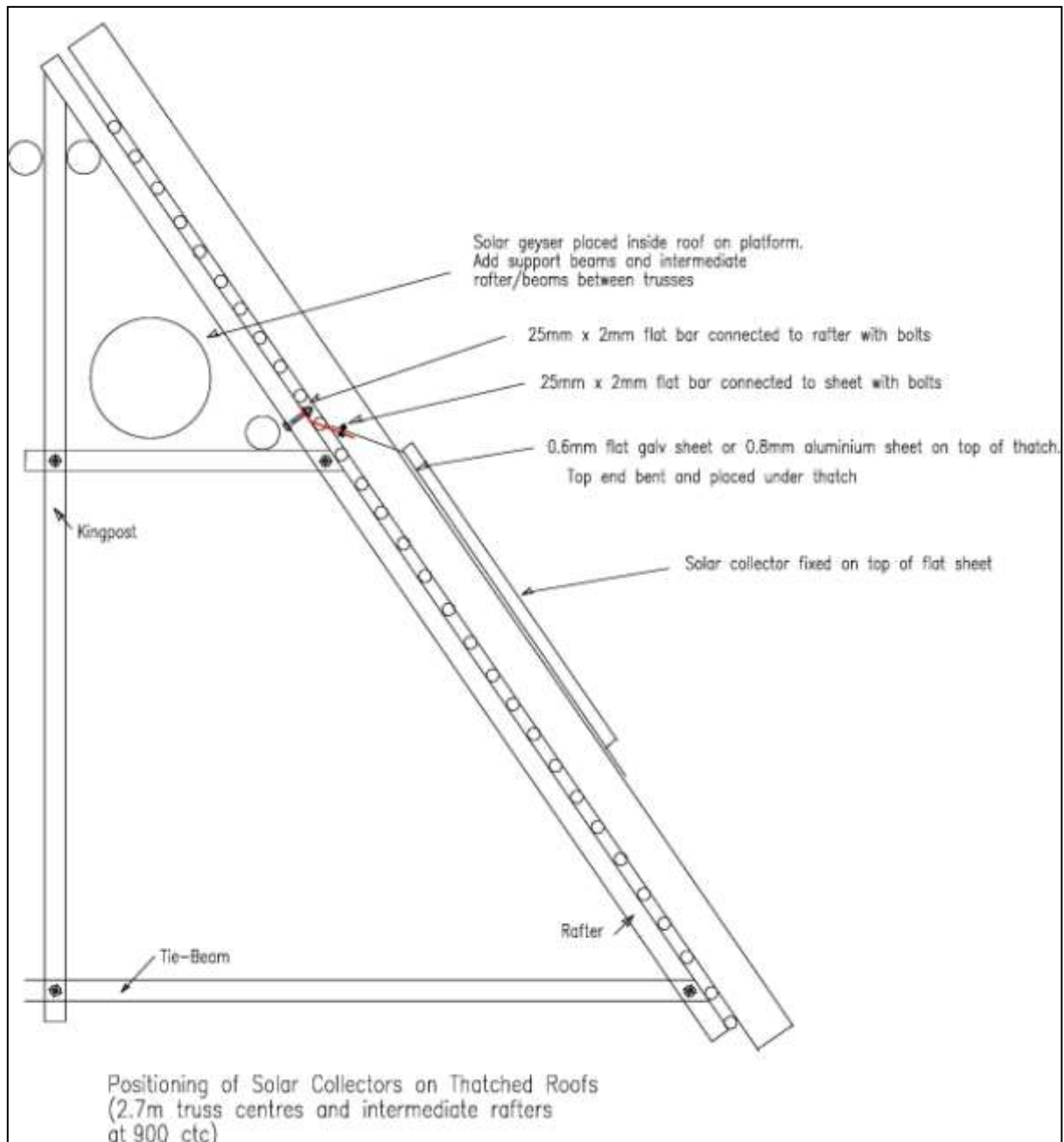

SITE SAFETY

Safety harnesses should always be worn by anyone working on the roof. Site safety should conform to construction site safety and security regulations.



Correct, with safety harnesses



Incorrect, without safety harnesses

THATCH ROOF SERVICING AND MAINTENANCE

The Thatchers Association of South Africa, strongly recommends that only experienced thatch contractors be appointed to install and service thatch roofs. The Pull & Combing process must be well supervised, since inexperienced or uninformed thatchers could take shortcuts that could ultimately destroy the roof.

The Insurance companies request that maintenance must and should be done regularly on a thatch roof. The question arises as to what is expected that should be done to maintain the roof. There has always been a controversy about the brushing and combing method. As there are two types of thatch roofs, namely Cape reed and thatching grass. Is there a golden rule that applies, and at what intervals should this maintenance happen? Presently many of the methods used actually reduces the life span of the roof.

With proper maintenance at required intervals, a well-constructed thatch roof should have a long lifespan.

Apart from keeping the surface of the thatch clear of creepers and other vegetation, maintenance has to be done on the thatch itself. Deterioration is usually evident from the untidy appearance of the covering.

Inspections of the roof, in particular of areas such as valleys, the areas under trees, and areas with slopes of less than 45°, should be carried out regularly to determine the condition of the thatch layer. In general, the rate of loss in thickness may be assumed to be in the order of 20 mm to 25 mm in cover over seven to nine years. For a 175 mm-thick thatch layer, the thatching twine will generally be located in the middle of the layer (about 80-100 mm below the top surface) as the twine could eventually become exposed after 20 years or so.

The lifespan of the thatch will be prolonged by regular inspections which will indicate when a Pull & Comb is required, with a thatching spade (leggatt).

One needs to understand the technical detail of a thatch roof before you merely allow an unqualified thatcher comb a roof. Every combing process, unless properly done, reduces the cover over the sway, in other words the functional thickness of a roof and thus lifespan.

A GUIDE TO THATCH CONSTRUCTION IN SOUTH AFRICA

The very first course of action to take is to inspect the general length of the thatch or reed. If found to be long enough, the thatch layers can be pulled down. This aspect of a thatch roof is critical, because the length of the stem below the twine actually has a direct bearing on the lifespan of the roof. Next, the binding twine must be tightened on the underside of the roof, and only then can the combing process begin. See photos below.



Looking at the photo above one can see top left part of the roof already serviced, the middle part still needing to be serviced and the bottom area with layers pulled back.



Tightening of twine after pulling down of outer layer of bundles

A GUIDE TO THATCH CONSTRUCTION IN SOUTH AFRICA



The photo below clearly showing how the thatch is raised after servicing.



THATCH ROOF REPAIRS – **OVER/RE-THATCH**

(The following does not apply to Cape Reed roofs, there must never be a second layer added to buildings thatched with Cape Reed)

All rotted thatching material should be completely stripped out during maintenance and replaced with new, tightly packed, mature material. The entire roof should then be cleaned of loose material, by brushing prior to the application of any new thatch layer.

The original design of the roof structure needs to be adequate to take the additional load of a second layer of thatch. IT IS IMPORTANT TO INSPECT THE INTEGRITY OF THE TIMBER STRUCTURE TO CARRY THE ADDITIONAL LOAD OF A SECOND LAYER BEFORE IT IS ADDED.

Re-dressing of the thatch cover (adding of a new thatch layer over the original layer) becomes necessary when decay has reached the stage when the fixings become exposed on the surface.

Once the fixings are exposed, rainwater can be channelled down through the thatch by running down the stitching twine into the thatch layer and into the building. Exposure of the fixings will result not only in the weathering of the twine stitching, but also in the deterioration of the entire roof cover when the compaction of the thatch is lost. Because thatch is a natural material, it will deteriorate at a given rate, depending on the environmental conditions for that area.

The thickness of a second layer, termed either an overlay or an over thatch, shall be in accordance with table 2 (see columns 2, 3 and 5 of table 2 in SANS 10407:2015 Edition 2) The most important point being, that the cover over the sway, be no less than 70 mm.

If a second layer is found it shall first be removed before the overlay or over thatch is applied (i.e. there shall never be more than 2 layers of thatch on the roof structure).

A GUIDE TO THATCH CONSTRUCTION IN SOUTH AFRICA



It is important to cut back any trees or bushes overhanging a thatch roof, to ensure that shadowing is not cast on the roof and thus cause rotting. Branches too close or touching the roof will also damage the thatch when the wind blows. Keeping the roof clear of branches, will increase the lifespan of the roof.



FIRE SAFETY

SAFETY DISTANCES

Safety Distances from other structures and boundaries as per SANS 10400-T

4.12.2 Thatched roofs

4.12.2.1 The safety distances derived from 4.2 shall, notwithstanding the occupancy classes given in table 2, be based on a high fire load where the thatch is unprotected and value A in the formula will be based on the total facade area of the building facing the boundary, irrespective of the wall type or openings and including the roof, . Where the thatch is provided with a fire-retardant system, tested in accordance with ASTM E108 the safety distances shall be based on the following fire loads,

- a) Test result A – low fire load
- b) Test result B – medium fire load
- c) Test result C – high fire load

NOTE A test result C is equivalent to an unprotected roof.

4.12.2.2 Notwithstanding the requirements of 4.12.1, a thatched lapa that has a roof plan area of less than 20 m², which is free standing and not attached to any other building shall not be erected closer than

- a) 1,0 m to any boundary, and
- b) The safety distance from any building derived from 4.2, unless a free-standing masonry or concrete wall that has a height greater than 0,3 m above the bottom line of the roof and which extends at least 1,0 m on either side of the lapa is erected.

4.12.2.3 A competent person (fire engineering) shall perform a rational assessment to determine the acceptability of erecting a thatched building against an existing building.

4.12.2.4 Buildings and lapas with a thatched roof plan area greater than 300 m² or which are closer than the greater of 4,5 m to any boundary and the safety distances from an existing building derived from 4.2, shall be provided with additional fire

A GUIDE TO THATCH CONSTRUCTION IN SOUTH AFRICA

retardant systems that are acceptable in relation to the actual roofing system that is to be used, and maintained as specified by the manufacturer of such systems.

4.12.2.5 Buildings and lapas with thatched roofs in areas with a lightning flash density greater than 7 (see SANS 10313) shall be provided with a lightning protection system designed and installed by competent persons in accordance with the relevant requirements of SANS 10313 and SANS 62305-3.

4.12.2.6 Buildings and lapas in which conductors (wire sways) are used in the thatch layer shall, in areas with a lightning flash density greater than 3 (see SANS 10313), be provided with a lightning protection system, designed and installed by competent persons in accordance with the relevant requirements of SANS 10313 and SANS 62305-3.

SERVICES

Electrical power supply and telephone cables should enter the building by means of underground ducts/conduits, and all electrical wiring in the roof space should be run in plastic conduits, with all junction boxes properly sealed.

USE OF CONDUCTORS

The presence of steel or any type of conductor in the roof structure presents a lightning conduction hazard if the roof is not protected. It is therefore essential that the SANS regulations be followed rigorously to prevent any damage from lightning.

Under no circumstances should steel pipes, cables or electric wiring be in direct contact with the thatch. Electrical and other services (telephone and TV) should always enter a building at ground level. No cables or wiring to be run through the thatch.



Multiple lightning conductors.

LIGHTNING PROTECTION SYSTEM (LPS)

For Fire safety reference must be made to SANS 10400-T. It is crucial to ensure your design and installation is LPS compliant.

At least lightning protection level III (see SANS 62305-3) will apply in the case of thatched structures. If a metallic mast is used as an LPS, it shall be designed in Accordance with SANS 10225. Protection shall be arranged by one or more free-standing masts. The zone of protection of the mast(s) shall include gable ends, chimneys, antennas, vent pipes and any other metal object. Telephone wires, overhead service connections to the electricity supply or other overhead metal wires or pipes shall not enter the structure through or close to the thatch. The distance from the mast to the thatch shall be not less than 1 000 mm.

Metals used in the construction of a thatched roof shall be bonded and earthed. Water pipes, vent pipes, tanks, gas pipes, antennas, telephone and bell wires, burglar alarms and electrical wiring and conduit within 1 000 mm of the thatch shall be shielded, bonded and earthed, according to SANS 10142-1.

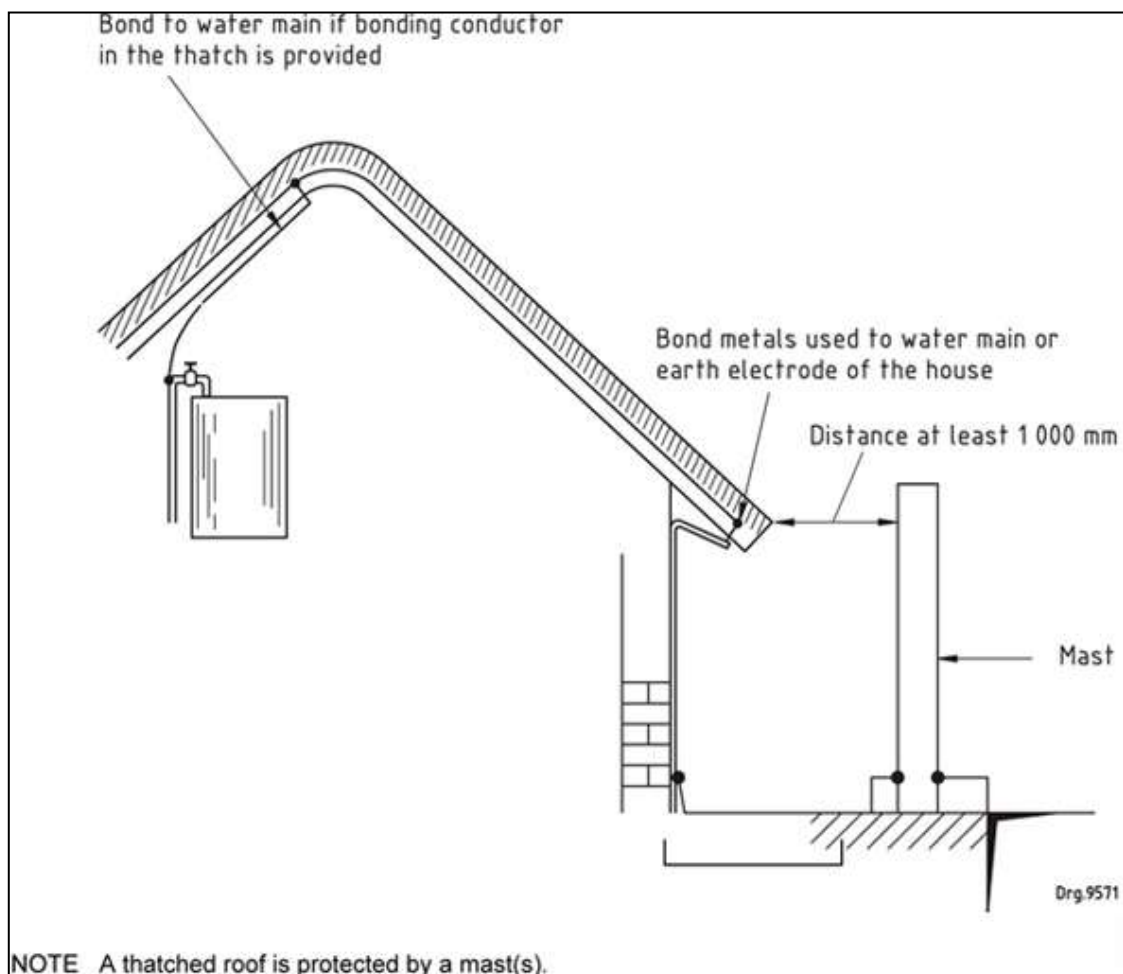

LIGHTNING GROUND FLASH DENSITY N_g

Table C.1 — Lightning ground flash density					
1	2	3	4	5	6
Town	N_g	Town	N_g	Town	N_g
Aberdeen	1,8	Gobabis	2,6	Paarl	0,2
Albertinia	0,5	Golden Gate	6,4	Petrus Steyn	4,4
Alexandria	0,8	Grabouw	0,2	Pietermaritzburg	7,0
Aliwal North	5,3	Graaff-Reinet	2,5	Piet Retief	11,7
Aranos	1,6	Grahamstown	1,4	Piketberg	0,2
Aroab	1,7	Greytown	5,5	Polokwane (Pietersburg)	3,6
Barberton	7,5	Groblersdal	5,1	Pongola	6,3
Beaufort West	1,7	Harding	5,5	Port Alfred	1,4
Belfast	7,3	Harrismith	9,4	Port Elizabeth	0,9
Bela Bela	7,5	Heidelberg (WC)	8,0	Potchefstroom	7,0
Benoni	7,5	Heilbron	5,8	Pretoria	7,5
Bergville	6,3	Hermanus	0,1	Prieska	3,0
Bethal	8,6	Hluhluwe	6,0	Prince Albert	0,6
Bethlehem	6,4	Hoedspruit	2,8	Queenstown	5,2
Bethulie	3,3	Humansdorp	1,1	Reddersburg	6,4

A GUIDE TO THATCH CONSTRUCTION IN SOUTH AFRICA

Bloemfontein	5,2	Irene	7,2	Richards Bay	5,2
Bloemhof	4,8	Jagersfontein	2,2	Richmond (KZN)	8,0
Blyderivierspoort	4,5	Johannesburg	7,5	Riversdale	0,2
Boksburg	7,5	Jozini	5,6	Roedtan	4,9
Brakpan	7,5	Keetmanshoop	1,2	Rustenburg	8,1
Brandvlei	0,9	Kempton Park	7,5	Sabie	3,2
Brits	8,0	Keiskammahoek	2,0	Satara	1,5
Bultfontein	3,6	Kimberley	4,8	Schweizer-Reneke	5,6
Burgersdorp	3,3	King William's Town	1,1	Scottburgh	3,0
Butterworth	0,9	Klerksdorp	7,0	Senekal	4,7
Cala	5,2	Knysna	0,4	Sishen	3,4
Caledon	0,2	Komatipoort	2,6	Skukuza	2,3
Calvinia	0,7	Kroonstad	5,8	Somerset East	0,8
Cape Town	0,3	Krugersdorp	7,0	Springbok	0,6
Carletonville	7,5	Kuruman	3,0	Springs	7,5
Carnarvon	1,1	Ladybrand	5,4	Standerton	7,6
Carolina	9,0	Ladismith (WC)	0,7	Stanger	3,5
Cathcart	1,6	Ladysmith (KZN)	9,0	Stellenbosch	0,3
Cedara	8,0	Laingsburg	0,6	Steytlerville	1,7

A GUIDE TO THATCH CONSTRUCTION IN SOUTH AFRICA

Ceres	0,2	Lichtenburg	5,5	Sutherland	0,9
Christiana	6,4	Loskop	4,3	Swakopmund	0,5
Colenso	7,8	Lüderitz	0,4	Tarkastad	3,4
Colesberg	3,0	Lydenburg	5,0	Thabazimbi	2,1
Cradock	5,8	Machadodorp	8,7	Theunissen	5,2
De Aar	2,5	Mafikeng	5,6	Touws River	0,3
Delareyville	5,4	Makhado	1,5	Tsumeb	4,0
Donnybrook	8,5	Malmesbury	0,1	Tzaneen	4,1
Doornfontein	7,3	Mandini	3,4	Umtata	3,0
Dordrecht	2,6	Margate	1,8	Uniondale	0,6
Douglas	4,0	Marikana	6,9	Upington	2,2
Dundee	9,2	Matatiele	6,6	Utrecht	9,0
Durban	4,4	Middelburg (EC)	3,3	Ventersdorp	5,6
East London	1,6	Middelburg (Mpumalanga)	4,6	Vereeniging	7,5
Edenvale	5,6	Modimolle	7,0	Victoria West	1,4
Elliott	4,2	Mokopane	3,4	Villiersdorp	0,4
Empangeni	4,1	Molteno	1,6	Vredendal	0,2
Ermelo	9,0	Montagu	0,2	Vryburg	3,0
Eshowe	5,3	Mooi River	6,9	Vryheid	8,9

A GUIDE TO THATCH CONSTRUCTION IN SOUTH AFRICA

Evander	8,5	Mookgopong	6,0	Walvis Bay	0,2
Flagstaff	4,9	Mossel Bay	0,5	Welkom	5,0
Fort Beaufort	1,4	Murraysburg	1,9	Willowmore	1,5
Fraserburg	1,3	Nelspruit	2,7	Windhoek	2,3
George	1,5	Nossop	2,2	Witbank	7,5
Georgedale	5,6	Noupoort	7,4	Zeerust	4,2
Germiston	7,5	Ohrigstad	4,2		
Giant's Castle	13,0	Oshakati	2,3		
Gobabes	0,2	Oudtshoorn	0,5		

A GUIDE TO THATCH CONSTRUCTION IN SOUTH AFRICA

LPS installation safety report will be issued by a qualified person.

Amdt 1

1. Location																							
Physical address:																							
Name of building:																							
Erf/Lot No.:					Suburb/Township:																		
District/Town/City					Province:																		
Type of inspection:		Repeat <input type="checkbox"/>			Additional <input type="checkbox"/>			Visual <input type="checkbox"/>															
Acceptance <input type="checkbox"/>		Design <input type="checkbox"/>			During construction <input type="checkbox"/>																		
Lightning ground flash density (N_g): (Flashes/km ² /year)				Accepted annual frequency of lightning flashes to structure (N_c):																			
Protected space (description):																							
Risk assessment done for system?		Yes <input type="checkbox"/>		No <input type="checkbox"/>		Risk assessment report attached?		Yes <input type="checkbox"/>		No <input type="checkbox"/>													
2. Risk assessment																							
User-specified acceptable risk				User-calculated risks:			Risk of direct strike R_D	Risk of indirect strike R_I	Calculated risk R														
Tolerance on risk: R_T	1	Loss of human life					10 ⁻³	1															
	2	Loss of services					10 ⁻³	2															
	3	Loss of cultural heritage					10 ⁻³	3															
3. Air-termination system																							
Thatched roof:		Yes <input type="checkbox"/>	No <input type="checkbox"/>	Metal roof: Yes <input type="checkbox"/>			No <input type="checkbox"/>	Hazardous location: Yes <input type="checkbox"/>			No <input type="checkbox"/>												
Flat roof:		Yes <input type="checkbox"/>	No <input type="checkbox"/>																				
LPS level:		I <input type="checkbox"/>		II <input type="checkbox"/>		III <input type="checkbox"/>		IV <input type="checkbox"/>															
Height of structure:			Height of mast/catenary:				Number of mast(s):																
Mast design in compliance with SANS 10225:				Supplier of mast:				Tel. No.:															
Air-termination system:				Protective angle α :				Rolling sphere radius, m:															
Material used:		Lead <input type="checkbox"/>	Steel (stainless or galvanized) <input type="checkbox"/>		Titanium <input type="checkbox"/>	Copper <input type="checkbox"/>	Aluminium <input type="checkbox"/>	Zinc <input type="checkbox"/>															
4. Down conductor system																							
Material used:		Steel (stainless or galvanized) <input type="checkbox"/>		Copper <input type="checkbox"/>		Aluminium <input type="checkbox"/>		Spacing between conductors				m											
Size of DTS conductor used, mm ² :				Is existing structure used as down conductor?			Yes <input type="checkbox"/>	No <input type="checkbox"/>	Description:														
Reinforced concrete/metal used?		Yes <input type="checkbox"/>	No <input type="checkbox"/>																				
Mesh design:		Number of down conductors:		Spacing between ring conductors:		Accessible joints/terminations:			Yes <input type="checkbox"/>	No <input type="checkbox"/>													
Accessible joints/terminations:				Pop-riveted <input type="checkbox"/>			Soldered <input type="checkbox"/>																
NOTE The following abbreviation has been used:																							
DTS down conductor termination system																							

Amdt 1

A GUIDE TO THATCH CONSTRUCTION IN SOUTH AFRICA

Amdt 1

5. Earth-termination system			
Earthing arrangement	Type A	Type B	Particular conditions:
			Reason for earthing arrangement:
Final equivalent earth resistance obtained:		Ω	Soil resistivity:
Ωm			
6. Lightning equipotential bonding			
Equipotential bonding bar installed:		Yes <input type="checkbox"/>	No <input type="checkbox"/>
System connected to bonding bar installed:	Telecommunication <input type="checkbox"/>	Pipes <input type="checkbox"/>	Electrical <input type="checkbox"/> Equipment <input type="checkbox"/>
Material used:	Steel (stainless or galvanized) <input type="checkbox"/>	Copper <input type="checkbox"/>	
Conductor size used to connect bonding bar to ETS, mm ² :		Conductor size used to connect metal installation to ETS, mm ² :	
7. Surge protective devices (SPDs)			
Design drawing No.:		Main incomer distribution board: Load current A	Prospective short-circuit current rating kA
SPD, class I: nominal a.c. voltage U_N V	V	Impulse current I_{imp} : kA (10/350 μs)	Max. back-up fuse current I_k kA
		Voltage protection level at I_{imp} : kV	Follow current extinguishing capability: kA _{rms}
SPD, class II: nominal a.c. voltage U_N V	V	Nominal discharge current I_n kA (8/20 μs)	Max. mains overcurrent protection A
		Voltage protection level at I_n : V	Temporary overvoltage (TOV) U_T V/5 s
8. Certification			
I/We, being the person(s) responsible for the design ^a , installation ^a , inspection ^a , testing ^a , of the lightning protection system (LPS), am/are competent to certify that the LPS complies with the requirements of SANS 10313.			
^a Delete where not applicable.			
9. Details of LPS designer			
Name:		ID No.:	Company:
Tel No.:		Signature:	Date:
10. Details of LPS installation installer			
Name:		ID No.:	Company:
Tel No.:		Signature:	Date:
11. Details of fixed electrical Installation			
Any work performed on the fixed electrical installation with regard to the LPS shall be witnessed by an accredited person.			
Installation safety report No.:		Date of installation safety report:	
12. Approval signature			
Name of lighting protection inspector:		Company:	
Tel No.:		Date:	
ID No.:		Signature:	
NOTE The following abbreviations have been used:			
DTS down conductor termination system			
ETS earth-termination system			

Amdt 1

A GUIDE TO THATCH CONSTRUCTION IN SOUTH AFRICA

LPS installation maintenance certificate will be issued by a qualified person.

Amdt 1

1. Location												
Physical address:												
Name of building:												
Erf/Lot No.:			Suburb/Township:									
District/Town/City:			Province:									
LPS level:	I	<input type="checkbox"/>	II	<input type="checkbox"/>	III	<input type="checkbox"/>	IV	<input type="checkbox"/>	Date of last inspection:			
Type of inspection:	Repeat	<input type="checkbox"/>	Additional	<input type="checkbox"/>	Visual	<input type="checkbox"/>	Acceptance	<input type="checkbox"/>				
2. Details of LPS installation installer												
Name:		ID No.:		Company:								
Tel No.:		Signature:		Date of installation:								
3. Details of fixed electrical installation												
Any work performed on the fixed electrical installation with regard to the LPS shall be accompanied by an Installation safety report issued by an accredited person.												
Original Installation safety report No.:			Date of Installation safety report:									
4. Maintenance of LPS structure												
4.1 Air-termination system (ATS)												
Connection between ATS and down conductor:		Acceptable	<input type="checkbox"/>	Replaced	<input type="checkbox"/>	Refastened	<input type="checkbox"/>					
Material used:	Lead	<input type="checkbox"/>	Steel (stainless or galvanized)	<input type="checkbox"/>	Titanium	<input type="checkbox"/>	Copper	<input type="checkbox"/>	Aluminium	<input type="checkbox"/>	Zinc	<input type="checkbox"/>
Straightness of mast used:		Acceptable:	<input type="checkbox"/>	Replaced	<input type="checkbox"/>	Continuity of ATS:						
4.2 Down conductor system (DTS)												
Material used:		Steel (stainless or galvanized)	<input type="checkbox"/>	Copper	<input type="checkbox"/>	Aluminium	<input type="checkbox"/>	Electrical conductivity of conductors: Ω				
Size of DTS conductors used, mm ² :			Accessible joints/terminations:									
Electrical conductivity of shielding measures: Ω			Electrical conductivity of equipotential bonding lines: Ω									
If reinforced concrete/metal parts are used as down conductors, is conductivity still present?								Yes	<input type="checkbox"/>	No	<input type="checkbox"/>	
4.3 Earth-termination system												
Earthing arrangement:		Type A	<input type="checkbox"/>	Type B	<input type="checkbox"/>	Identification of earth connection points visible?		Yes	<input type="checkbox"/>	No	<input type="checkbox"/>	
Equivalent earth resistance, Ω :		Soil resistivity, $\Omega.m$:		Earth termination system visible: Yes <input type="checkbox"/> No <input type="checkbox"/>								
Connection between DTS and ATS:		Connections acceptable		<input type="checkbox"/>	Connections needed		<input type="checkbox"/>	Connections needed to be replaced ^a			<input type="checkbox"/>	
Safe dispersing of lightning current:				Yes				<input type="checkbox"/>	No			<input type="checkbox"/>
^a In the event of connections that were refastened or replaced, please provide a drawing that shows the locations of these connections.												

Amdt 1

A GUIDE TO THATCH CONSTRUCTION IN SOUTH AFRICA

Amdt 1

4.4 Lightning equipotential bonding			
Equipotential bonding bar inspected:		Acceptable <input type="checkbox"/>	Replaced ^b <input type="checkbox"/>
System connected to bonding bar:	Telecommunication <input type="checkbox"/>	Pipes <input type="checkbox"/>	Electrical <input type="checkbox"/> Equipment, describe:
Material used:	Steel (stainless or galvanized) <input type="checkbox"/>	Copper <input type="checkbox"/>	Connection between bonding bar, ETS and DTS: Acceptable <input type="checkbox"/> Repaired ^c <input type="checkbox"/>
Surge protective devices inspection:	Acceptable <input type="checkbox"/>	Damaged (reported to electrician) <input type="checkbox"/>	
Bonding of metal equipment checked:	Pipes <input type="checkbox"/>	Conduit <input type="checkbox"/>	Gutters <input type="checkbox"/> Roofs <input type="checkbox"/>
5. Approval signature			
Name of lightning protection inspector:		Company:	
Tel No.:		Date:	
ID No.:		Signature:	
NOTE The following abbreviations have been used:			
ATS air-termination systems			
DTS down conductor termination system			
ETS earth-termination system			
^b In the event of an equipotential bonding bar that was replaced, proof of correct installation and reconnection of equipment to the bonding bar shall be shown.			
^c In the event where the connection between the bonding bar, the ETS and the DTS was repaired, proof of the repair by accredited personnel shall be submitted.			

Amdt 1

SPARK ARRESTORS

A Spark Arrestor is stainless steel wire mesh inserted into the chimney at a minimum of 700 deep.

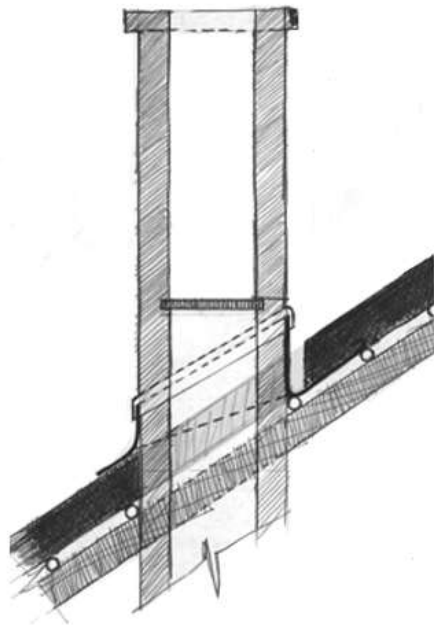
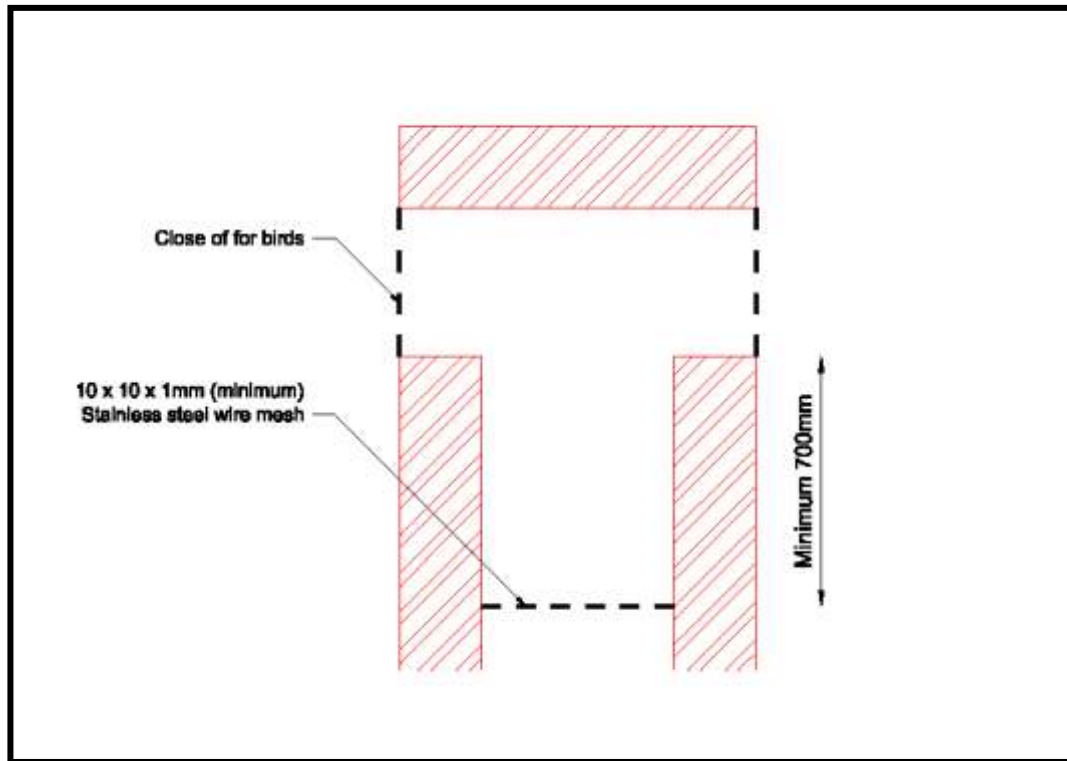

Typical Position of a Spark Arrestor.

It is recommended to have chimneys cleaned/swept at least once a year before winter season.

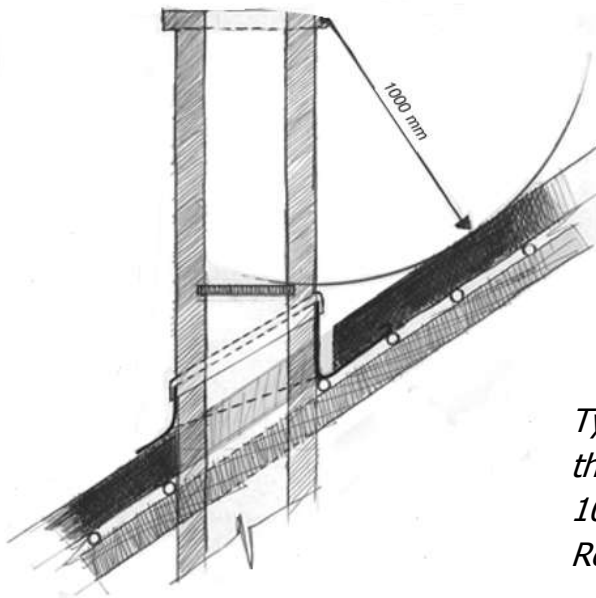

Typical section through chimney showing the minimum height above the thatch layer, 1000 mm as per National Building Regulations.

DRENCHER SYSTEMS

One of the best measures for preventing fires from spreading between thatched roofs is the installation of a drencher water system at the highest part of the roof. A dedicated drencher water system cascades water over and down all the exposed thatch in the event of a fire. While this may not save the property where a fire starts, it can prevent the spread of fire from one roof to another.

A manual or automatic system can be installed. Automatic systems often include smoke sensors which triggers the drencher from fire inside the dwelling. In areas where water pressure is not strong enough pumps can be installed or water can be pumped from swimming pools.

FIRE BLANKETS

The fire retardant blanket is an imported cloth, capable of resisting temperatures greater than 750 degrees centigrade is used. The cloth is woven continually throughout the thatched area and is completely covered with thatch and is therefore not visible. It is suggested that galvanized binding material is used instead of the traditional tarred twine which is highly flammable and therefore a fire hazard.

Using a fire blanket in the thatch roof is also taken into consideration by insurance companies when calculating insurance premiums.

ENERGY VALUES

Thatching in South Africa is a fast growing industry as we find more people looking for natural alternatives in construction. With it being a completely natural roofing product, thatching is growing in popularity in an environment where more members of the public are leaning towards natural materials used in construction, commonly known as "green design".

Thatch is by far the most natural product to use on your roof as it is harvested off the land and used without going through processes to create an actual roof covering. With the high thermal values of thatch there is no need for ANY other products to create insulation.

Looking at roofs from a "green" point of view the best roof one can put on a building would be a thatch roof. The structure is of timber poles storing CO₂ for the life of the building and then the actual thatch is also a natural product storing CO₂ with an added advantage. This being the fact that thatch grass is perennial. The thatch is expected to last for many years during which most of the CO₂ is not released.

By using thatch the roof is therefore designed for present use but also for future recycling. Dependence on resource intensive products and materials are also reduced. Thatch is an earth friendly, recyclable material. It is carbon free and a local material and by using the product we are truly supporting not only environmentally friendly construction but also supporting locally supplied materials.

Due to global warming, temperature variations in seasons are becoming more extreme. More insulation products are brought onto the market regularly but thatch still remains the most natural and eco-friendly solution. Aesthetically it is one of the most pleasing roof construction finishes. There is no other product which has these two characteristics as a raw product. With high thermal values, energy saving is guaranteed, dramatically reducing usage of heating and cooling. With talk of ever increasing electricity costs and possible power failures, a thatch roof impacts dramatically on energy savings.

High costs for a thatch roof compared to tiled roofs have also been a myth busted in recent projects. Thatch is proving to be a most effective roof covering with many costing items taken into consideration. Thatch requires no thermal insulation, guttering systems, fascias, soffits, ceilings, painting, etc. and thatch provides extra ceiling space due to the 45 deg pitch, giving a building a strong sense of volume.

A GUIDE TO THATCH CONSTRUCTION IN SOUTH AFRICA

With all these items taken into consideration a thatch roof is one of the most economical choices for a roof finish on the market.

Thatching makes use of materials that are naturally obtainable, i.e. grass or reed. In South Africa, only certain indigenous grasses are normally used.

There are many benefits to using thatch rather than a conventional roof. Thatch is a natural insulator and with a roof pitch of 45 deg. a great deal of extra loft space can be created. Various other materials are not required when using a thatch roof such as gutters, downpipes, fascias, soffits, ceilings, cornices, painting of such finishing etc. Taking all this into consideration makes a thatch roof option a very viable one and adding the fact that it is an energy saving option as well, should be reason enough for more people to opt for a thatch roof. Part of the calculations submitted to the municipality is what the architect will calculate which includes various energy level calculations.

Another myth about thatch which is being busted on a regular basis is the cost of insurance. With various ways to incorporate fire protection systems into the roof, insurance is brought down drastically by insurance companies.

Going "green" one need to consider opting for more natural solutions to construction methods and materials. There is no overnight cure to restoring our planet, but by opting for a thatch roof one is definitely on the right track to making a difference.

MINIMUM TOTAL R-VALUES OF ROOFS

U Values and R Values are calculated on submission of building plans to the municipality by the architect as part of the calculations required. Both are energy values. U Value measures how effective a material is an insulator, thermal conductivity. The lower the U-value is, the better the material is as a heat insulator. This thermal conductivity is all about how quickly heat is lost from it, and is measured in watts per m² per Kelvin.

The R Value refers to thermal resistance. The R-value depends on the type of material, its density and thickness. Tiny air particles trapped in the insulating material resist the movement of heat (and cold). The higher the R-value, the better the insulation is at reducing heat flow.

A thatch roof functions as both an insulated roof and a ceiling. The roof will ensure that the building is cool in summer and warm in winter, since thatch has a high

A GUIDE TO THATCH CONSTRUCTION IN SOUTH AFRICA

insulation value. A thatch roof shall receive the minimum total R Value specified in the table below for the direction of heat flow.

From the results of a test report ASTM C 518-10 by TTL dated 11 June 2013, the K Value of a thatched roof is:

$$K = 0.056 \text{ W}/(\text{m.K})$$

The required thickness (D(m)) to comply with SANS 10400- XA is therefore:

DESCRIPTION	Climatic Zone 1	Climatic Zone 2	Climatic Zone 3	Climatic Zone 4	Climatic Zone 5	Climatic Zone 6
Minimum required R-Value (m ² .K/W)	3.7	3.2	2.7	3.7	2.7	3.5
Minimum required thickness for thatched roofs (mm)	207	179	151	207	151	196
Direction of heat flow	up	up	up & down	up	down	up

$$D(\text{m}) = R(\text{m}^2.\text{K}/\text{W}) \times k(\text{W}/(\text{m.K}))$$

However, if the thickness calculations above are less than the requirement in SANS 10407-2015 Edition 2 then the greater of the two shall apply. The difference in thickness will then have a positive energy influence on the building holistically.

The deemed-to-satisfy provisions are based on climate zones, including dry bulb temperatures; thermal neutrality; humidity and southern coastal condensation risk.

A GUIDE TO THATCH CONSTRUCTION IN SOUTH AFRICA

CLIMATE ZONES IN SOUTH AFRICA

OVERVIEW OF CLIMATIC ZONES		
Zone	Description	Major Centres
Zone 1	Cold Interior	Johannesburg, Bloemfontein
Zone 2	Temperate Interior	Pretoria, Polokwane
Zone 3	Hot Interior	Louis Trichardt, Nelspruit
Zone 4	Temperate Coastal	Cape Town, Port Elizabeth
Zone 5	Sub-Tropical Coastal	East London, Durban, Richards Bay
Zone 6	Arid Interior	Upington, Kimberley

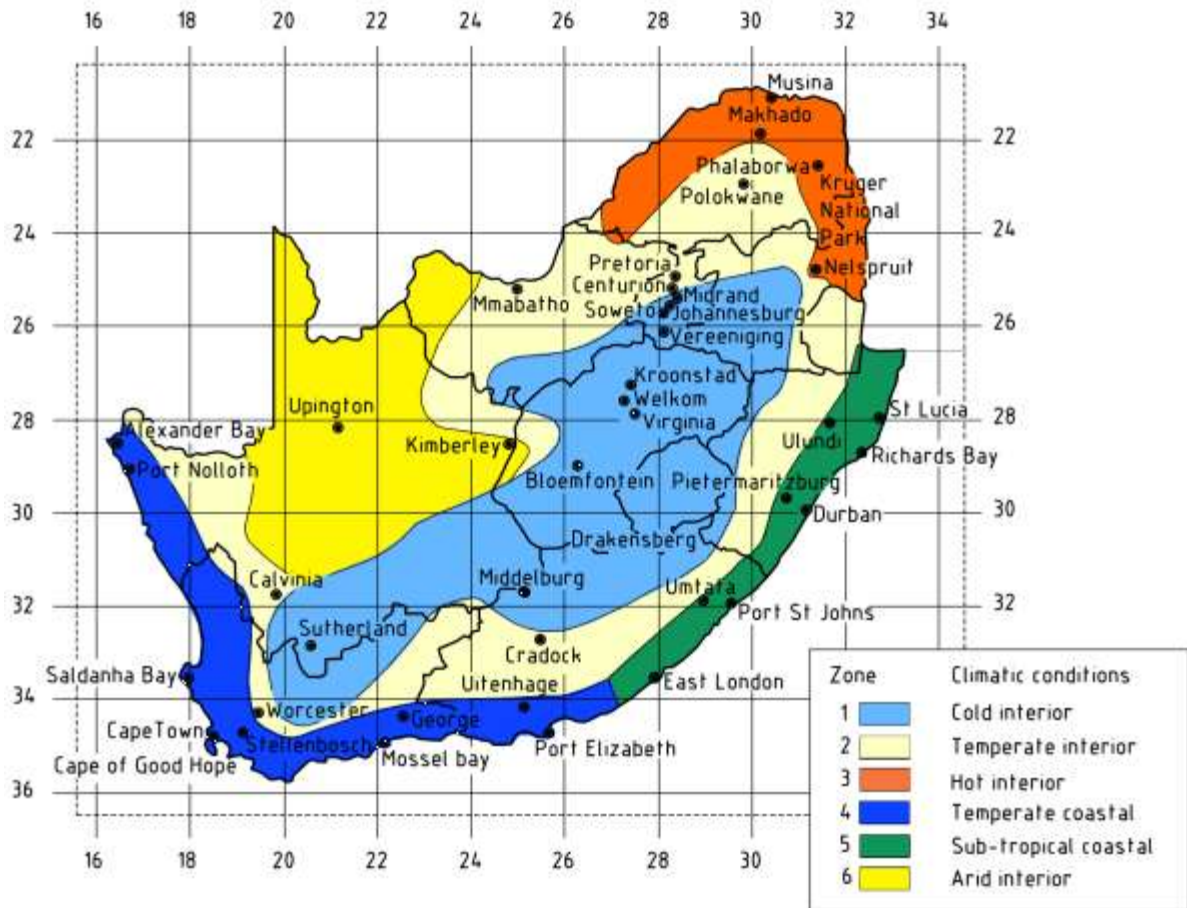

CONCLUSION

Thatching is a specialised field and professional guidance and workmanship is essential to ensure a successful project.

The Thatchers Association of South Africa (TASA) is there to assist the public as well as architects, engineers and other professionals with any queries.

ACKNOWLEDGMENTS & **REFERENCES**

SABS

Thatched roof construction: SANS 10407 - 2015 Edition 2

This standard covers the design of the supporting roofing structure and installation of thatch on roofing structures.

NOTE SANS 10400-L:2011 Edition 3 covers the design of roof structures, SANS 10400-T covers fire protection requirements, and SANS 10400-V covers chimney requirements. SANS 2001-CT2 covers the construction of the structural timberwork in the roof.

The following referenced documents are indispensable for the application of this document. For dated references, only the edition cited applies. For undated references, the latest edition of the referenced document (including any amendments) applies. Information on currently valid national and international standards can be obtained from the SABS Standards Division.

SANS 457-2, Wooden poles, droppers, guardrail posts and spacer blocks – Part 2: Softwood species.

SANS 457-3, Wooden poles, droppers, guardrail posts and spacer blocks – Part 3: Hardwood species.

SANS 820, Mild steel nails.

SANS 1083, Aggregates from natural sources – Aggregates for concrete.

SANS 1288, Preservative-treated timber.

SANS 1707-2, Sawn eucalyptus timber – Part 2: Branderling and battens.

SANS 1783-4, Sawn softwood timber – Part 4: Branderling and battens.

SANS 2001-CT2, Construction works – Part CT2: Structural timberwork (roofing).

SANS 10005, The preservative treatment of timber.

SANS 10155, Accuracy in buildings.

SANS 10183-1, Adhesives for wood – Part 1: Terminology.

SANS 10183-2, Adhesives for wood – Part 2: Requirements for structural applications.

SANS 10400-B, The application of the National Building Regulations – Part B: Structural design.

SANS 10400-K, The application of the National Building Regulations – Part K: Walls.

SANS 10400-L, The application of the National Building Regulations – Part L: Roofs.

A GUIDE TO THATCH CONSTRUCTION IN SOUTH AFRICA

SANS 10400-T, *The application of the National Building Regulations – Part T: Fire protection.*

SANS 10400-V, *The application of the National Building Regulations – Part V: Space heating.*

SANS 50197-1/EN 197-1, *Cement – Part 1: Composition, specifications and conformity criteria for common cements.*

Author of Main content and Photographs:

JOHN SMITH

Additional Information and Photographs contributed by:

TASA MEMBERS

“GUIDE TO GOOD THATCHING PRACTICE”

Published by the division of Building and Construction Technology

CSIR, Po box 395, Pretoria, 0001

Copyright vests in the CSIR

© 1998, CSIR, Pretoria

Boutek report no bou/e9806

SAWPA

How to plant a pole

DISCLAIMER

All thatched roofs are required to comply to the SANS 10407: 2015 Edition 2 specification pertaining to thatch roof construction. It must be built according to building plans designed and approved by a competent and registered professional engineer. The formal approval must be clearly visible on the design drawings and the latter must be duly signed by a competent person.

After completion of the construction of the thatched roof, a competent and qualified person must certify that the construction complies with the SANS 10407 specification, that it has been done according to the design drawings and that the quality of workmanship was of professional standard.

TASA cannot be held responsible for any structural defects, design failures, inferior workmanship or consequential damage that may directly or indirectly result from the above.